

# INSTRUCTION BOOK

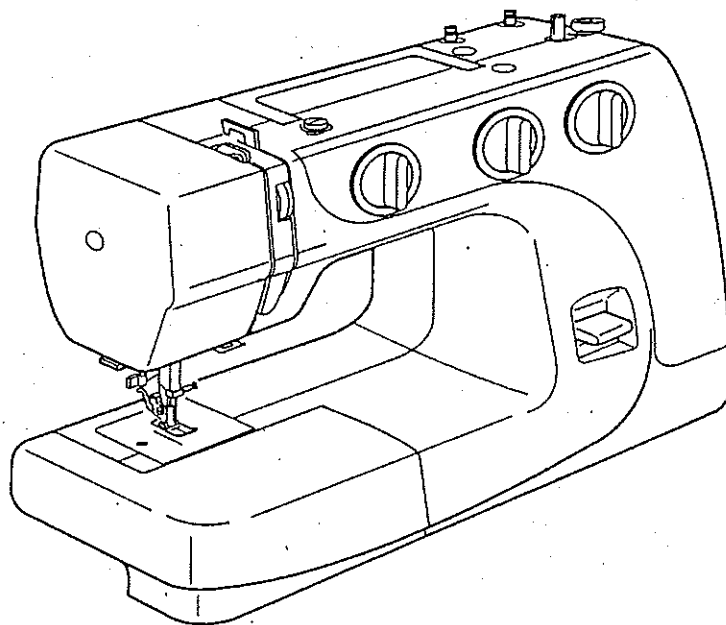

**Model J3-24**

# IMPORTANT SAFETY INSTRUCTIONS

When using an electrical appliance, basic safety precautions should always be followed, including the following:

Read all instructions before using this appliance.

## **DANGER**— To reduce the risk of electric shock:

1. An appliance should never be left unattended when plugged in. Always unplug this sewing machine from the electric outlet immediately after using and before cleaning.
2. Always unplug before replacing a sewing machine bulb. Replace bulb with same type rated 15 Watts.

## **WARNING**— To reduce the risk of burns, fire, electric shock, or injury to persons:

1. Do not allow children to play with the machine. The machine is not intended for use by children or infirmed persons without proper supervision.  
Do not allow to be used as a toy. Close attention is necessary when this sewing machine is used by or near children.
2. Use this appliance only for its intended use as described in this owner's manual.  
Use only attachments recommended by the manufacturer as contained in this owner's manual.
3. Never operate this sewing machine if it has a damaged cord or plug, if it is not working properly, if it has been dropped or damaged, or dropped into water.  
Return this sewing machine to the nearest authorised dealer or service centre for examination, repair, electrical or mechanical adjustment.
4. Never operate the appliance with any air opening blocked. Keep ventilation openings of this sewing machine and foot controller free from accumulation of lint, dust and loose cloth.
5. Never drop or insert any object into any opening.
6. Do not use outdoors.
7. Do not operate where aerosol (spray) products are being used or where oxygen is being administered.
8. To disconnect, turn all controls to the off ("O") position, then remove plug from outlet.
9. Do not unplug by pulling on cord. To unplug, grasp the plug, not the cord.
10. Keep fingers away from all moving parts. Special care is required around the sewing machine needle.
11. Always use the proper needle plate. The wrong plate can cause the needle to break.
12. Do not use bent needles.
13. Do not pull or push fabric while stitching. It may deflect the needle causing it to break.
14. Switch this sewing machine off ("O") when making any adjustment in the needle area, such as threading the needle, changing the needle, threading the bobbin or changing the presser foot, and the like.
15. Always unplug this sewing machine from the electrical outlet when removing covers, lubricating, or when making any other adjustments mentioned in this owner's manual.

## SAVE THESE INSTRUCTIONS

The design and specifications are subject to change without a prior notice.



"Please note that on disposal, this product must be safely recycled in accordance with relevant National legislation relating to electrical/electronic products. If in doubt please contact your retailer for guidance."

(European Union only)

# TABLE OF CONTENTS

<b>SECTION 1. ESSENTIAL PARTS</b>	
Names of Parts .....	2
<b>SECTION 2. GETTING READY TO SEW</b>	
Extension Table .....	3
Standard Accessories .....	3
Accessories Storage Box .....	3
Connecting the Machine to the Power Supply .....	4
Foot Control .....	4
Presser Foot Lifter .....	5
To Attach and Remove the Presser Foot .....	5
Changing Needle .....	6
Thread and Needle Chart .....	6
Setting Spool Pins .....	7
Removing or Inserting the Bobbin Case .....	7
Winding the Bobbin .....	8
Threading Bobbin Case .....	8
Threading the Machine .....	9
Needle Threader .....	10
Drawing Up Bobbin Thread .....	10
Balancing Needle Thread Tension .....	11
Adjusting Bobbin Thread Tension .....	11
Pattern Selector Dial .....	12
Stitch Length Dial .....	12
Stitch Width Dial .....	12
Reverse Stitch Button .....	13
Dropping the Feed Dog .....	13
<b>SECTION 3. BASIC SEWING</b>	
Straight Stitch Sewing .....	14
To Change Sewing Direction .....	14
Using the Seam Guides on the Needle Plate .....	15
Turning Square Corners .....	15
Variable Needle Position .....	15
Zigzag Stitching .....	16
<b>SECTION 4. UTILITY STITCHING</b>	
Overcasting .....	16
Tricot Stitch .....	17
Knit Stitch .....	17
Straight Stretch Stitch .....	18
Sewing on Buttons .....	19
Buttonhole .....	20-21
Corded Buttonhole .....	22
Zipper Application .....	23
Blind Stitch Hemming .....	24
<b>SECTION 5. DECORATIVE STITCHING</b>	
Shell Tuck .....	25
Stretch Stitch Patterns .....	25
Smocking .....	26
Box Stitching .....	26
Applique .....	27
Decorative Satin Stitch Pattern .....	27
<b>SECTION 6. CARE OF YOUR MACHINE</b>	
Dismantling and Assembling Hook Race Unit .....	28
Cleaning the Feed Dog .....	28
Sewing Light .....	29
Troubleshooting .....	30

## SECTION 1. ESSENTIAL PARTS

### Names of Parts

- 1 Reverse stitch button
- 2 Pattern selector dial
- 3 Stitch length dial
- 4 Stitch width dial
- 5 Bobbin winder stopper
- 6 Bobbin winder spindle
- 7 Spool pins
- 8 Bobbin winder thread guide
- 9 Thread guide
- 10 Thread take-up lever
- 11 Thread tension dial
- 12 Face plate
- 13 Thread cutter
- 14 Needle threader
- 15 Needle plate
- 16 Presser foot holder
- 17 Needle clamp
- 18 Needle
- 19 Presser foot
- 20 Extension table
- 21 Carrying handle
- 22 Handwheel
- 23 Power switch
- 24 Machine socket
- 25 Free arm
- 26 Buttonhole lever
- 27 Presser foot lifter

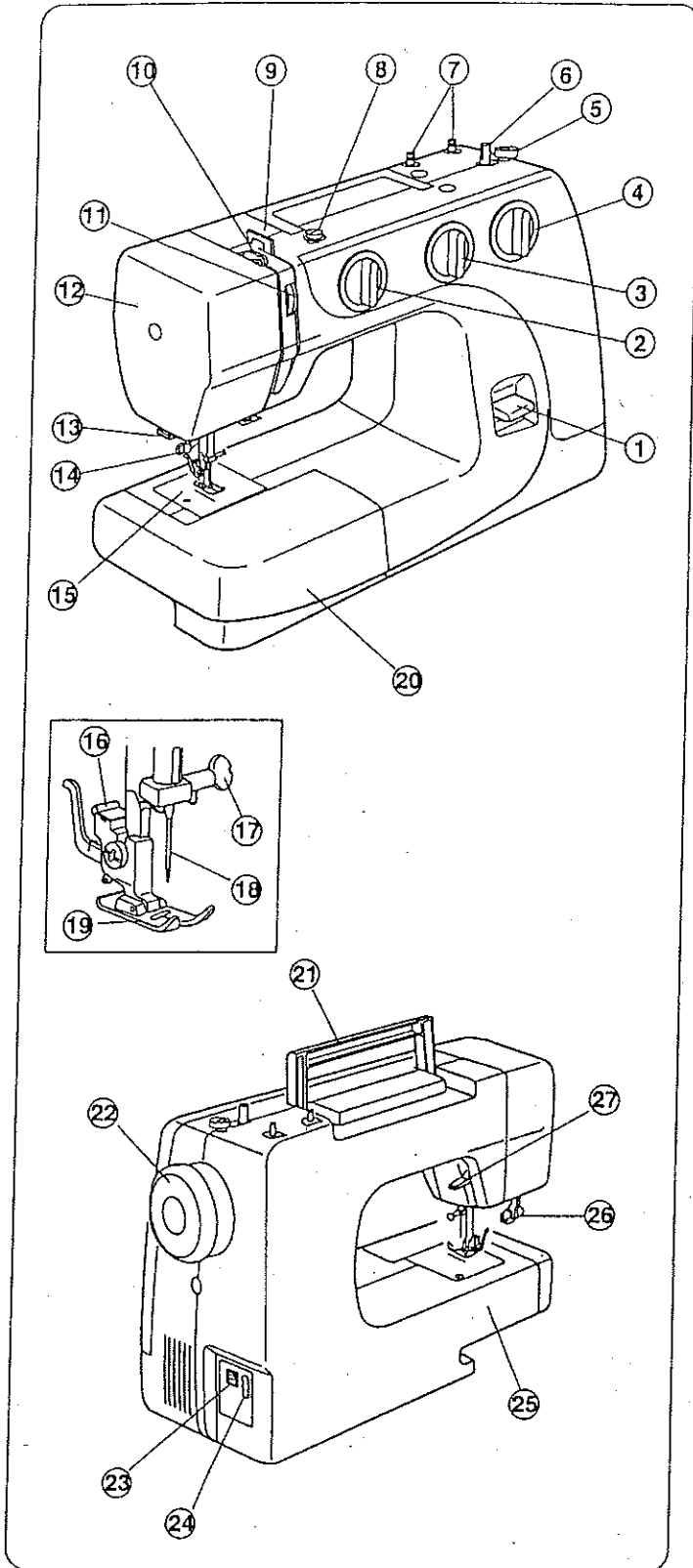

**Note :** The specifications are subject to change without prior notice.

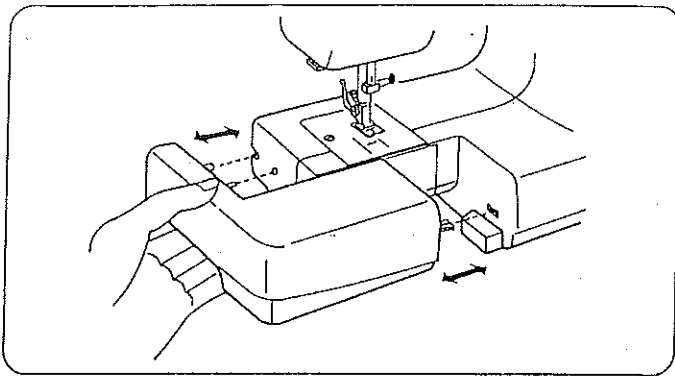

## SECTION 2. GETTING READY TO SEW

### Extension Table

The extension table provides added sewing surface and can be easily removed for free arm sewing.

#### Detaching the table:

Pull the table away from the machine.

#### Attaching the table:

Push the extension table until it snaps into the machine.

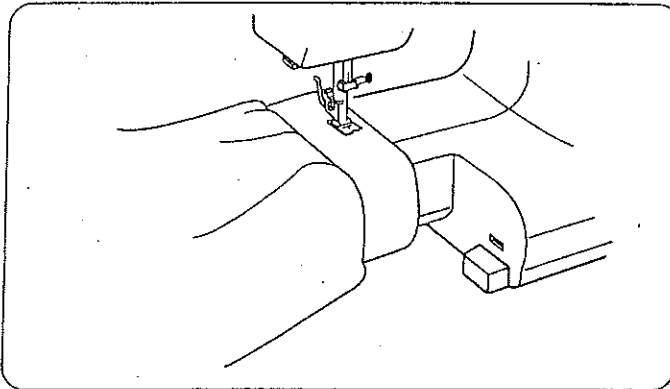

#### ● Advantages and uses of free arm sewing:

- Avoid fabric bunching around the needle when bartacking to reinforce pockets, plackets and waistlines.
- For stitching sleeves, waistbands, pant legs or any circular garment area
- For darning socks or mending knees, elbows or areas of wear in children's clothes

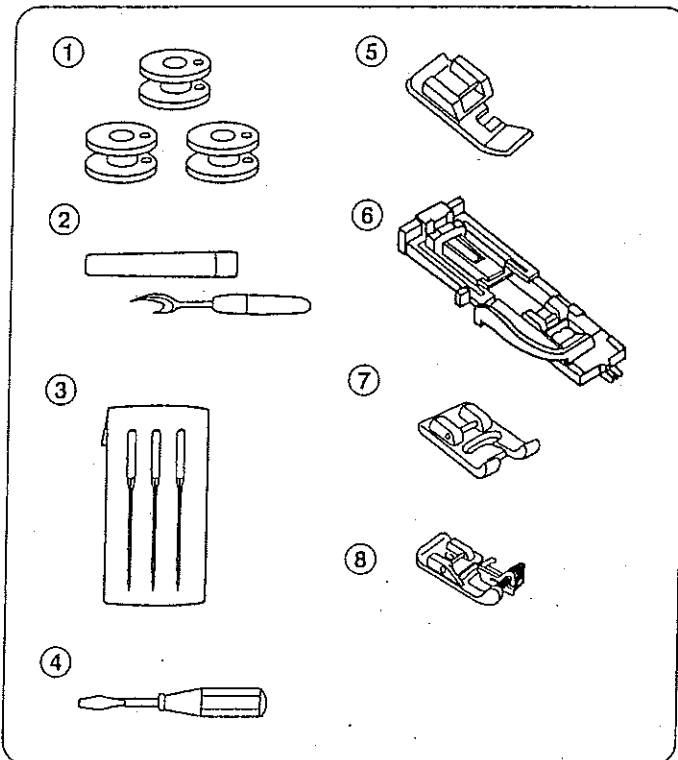

### Standard Accessories

- ① Bobbins
- ② Seam ripper
- ③ Set of needles
- ④ Screwdriver (small)
- ⑤ Zipper foot
- ⑥ Automatic buttonhole foot
- ⑦ Satin stitch foot
- ⑧ Blind hem foot

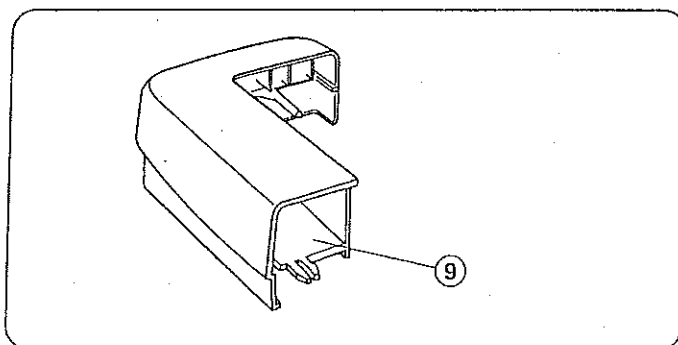

### Accessories Storage Box

Sewing accessories are conveniently located in the extension table.

- ⑨ Accessories storage box

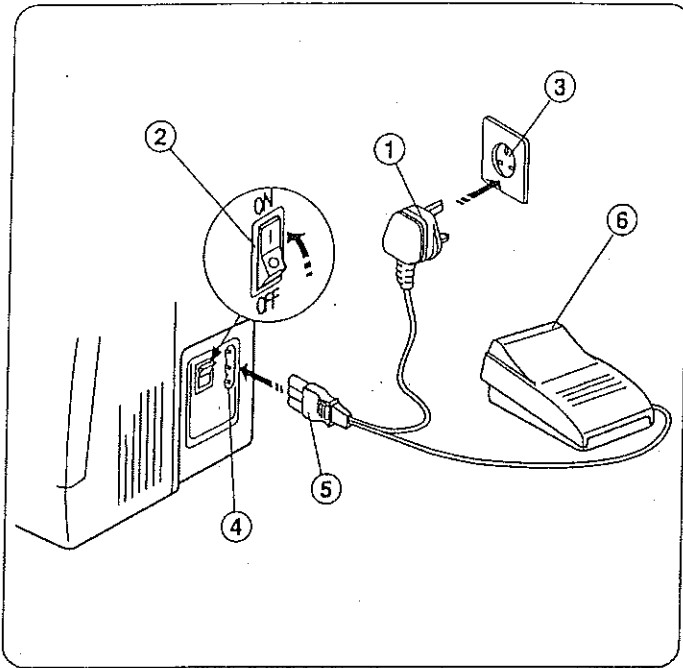

## Connecting the Machine to the Power Supply

Before connecting the power cord, make sure the voltage and frequency shown on the machine conform to your electrical power.

1. Turn off the power switch.
2. Insert the machine plug into the machine socket.
3. Insert the power supply plug into the outlet .
4. Turn on the power switch to turn on the power and sewing light.

- |                     |                  |
|---------------------|------------------|
| ① Power supply plug | ② Power switch   |
| ③ Outlet            | ④ Machine socket |
| ⑤ Machine plug      | ⑥ Foot control   |

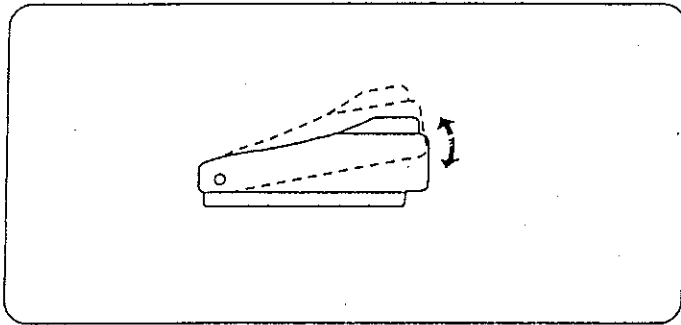

## Foot control

Sewing speed can be varied by the foot control.

The harder you press on the control, the faster the machine runs.

**Caution :** Do not place anything on the foot control, otherwise the machine will start advertently.

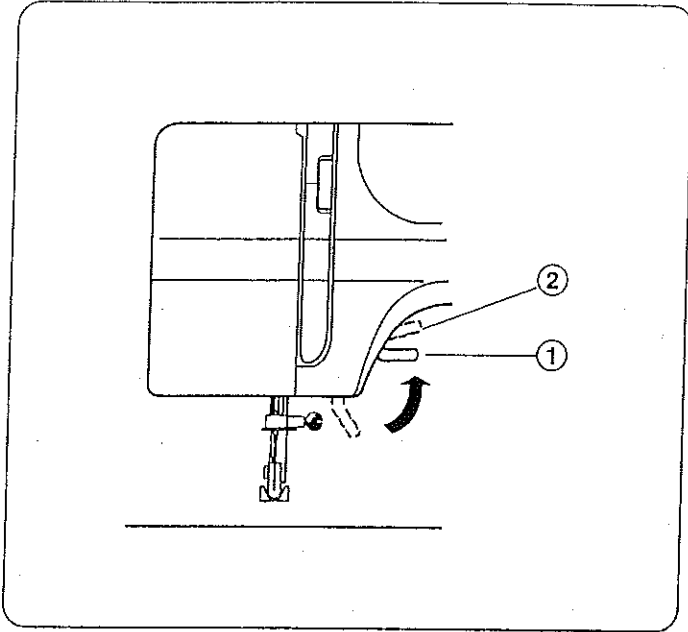

### Presser Foot Lifter

The presser foot lifter raises and lowers your presser foot. You can raise it about 0.6 cm (1/4") higher than the normal up position for easy removal of the presser foot or to help you to place heavy fabric under the foot.

- ① Normal up position
- ② Highest position

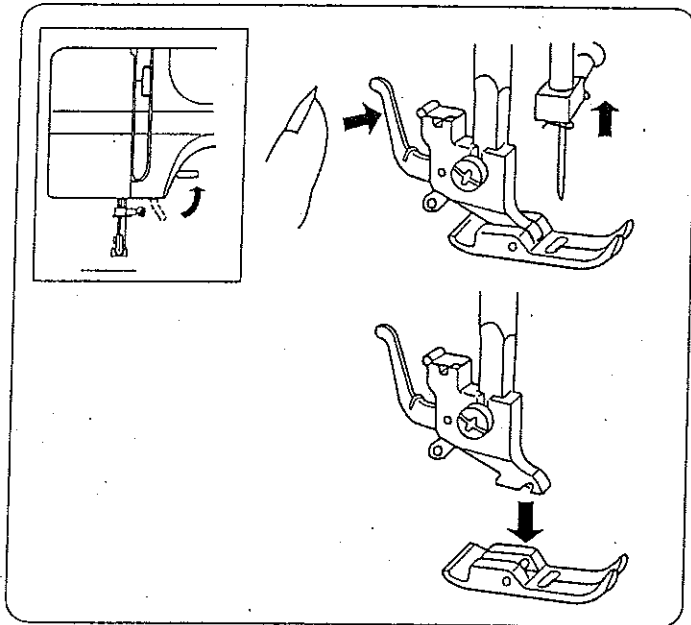

### To Attach and Remove the Presser Foot

#### To remove

Turn the handwheel toward you to raise the needle to its highest position.

Raise the presser foot.

Press the lever on the back of the foot holder.

The presser foot will drop off.

#### To attach

Place the presser foot so the pin on the foot lies just under the groove of the foot holder.

Lower the foot holder to lock the foot in place.

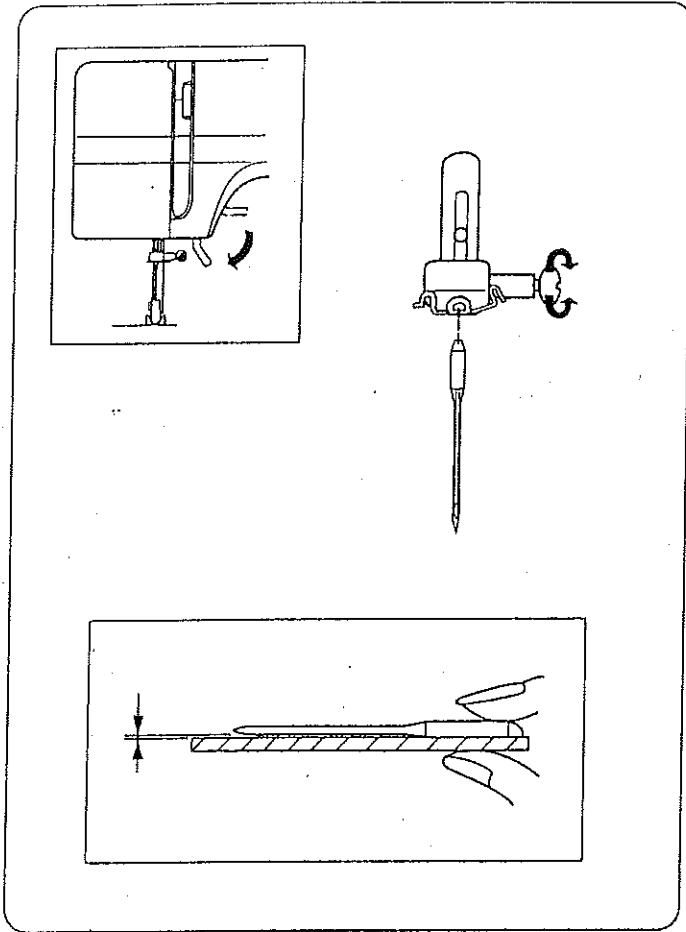

## Changing Needle

Raise the needle by turning the handwheel toward you and lower the presser foot.

Loosen the needle clamp screw by turning it counterclockwise. Remove the needle from the clamp.

Insert the new needle into the clamp with the flat side away from you.

When inserting the needle into the clamp, push it up as far as it will go and tighten the clamp screw firmly with the screwdriver.

- \* Check your needles frequently for barbed or blunted points. Snags and runs in knits, fine silks and silk-like fabrics are permanent and are almost always caused by a damaged needle.

## To check the needle

Place the flat side of the needle on something flat (needle plate, glass etc.). The clearance between the needle and flat surface should be consistent. Never use a bent or blunt needle.

	Fabrics	Thread	
<b>Light weight</b>	Crepe de Chine, Voile, Lawn, Organdy, Georgette, Tricot	Fine Silk	9
		Fine Cotton	or
		Fine Synthetic	11
		Fine Cotton Covered Polyester	
<b>Medium weight</b>	Linens, Cotton, Pique, Serge, Double Knits, Percale	50 silk	11
		50 to 80 Cotton	or
		50 to 60 Synthetic	14
		Cotton Covered Polyester	
<b>Heavy weight</b>	Denim, Tweed, Gabardine, Coating, Drapery and Upholstery Fabric	50 silk	14
		40 to 50 Cotton	
		40 to 50 Synthetic	16
		Cotton Covered Polyester	

## Thread and Needle Chart

- \* In general, fine threads and needles are used for sewing thin fabrics, and thicker threads and needles are used for sewing heavy fabrics. Always test thread and needle size on a small piece of fabric which will be used for actual sewing.
- \* Use the same thread for needle and bobbin.
- \* When sewing stretch, very fine fabrics and synthetics, use a BLUE TIPPED needle. The blue tipped needle effectively prevents skipped stitches.
- \* When sewing very fine fabrics, sew over a piece of paper to prevent seam puckering.



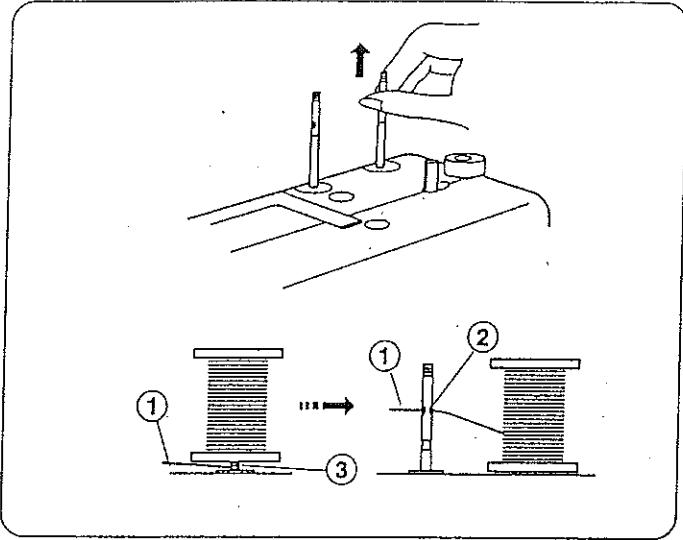

### Setting Spool Pins

The spool pins are used for holding the spool of thread in order to feed thread to the machine.

To use, pull up the spool pin. Push down for storage.

- ① Upper thread
- ② Hole
- ③ Tangle

**Note :** When using thread which has tendency to tangle around spool pin, thread through the hole of spool pin as shown.

The hole should face the thread spool.

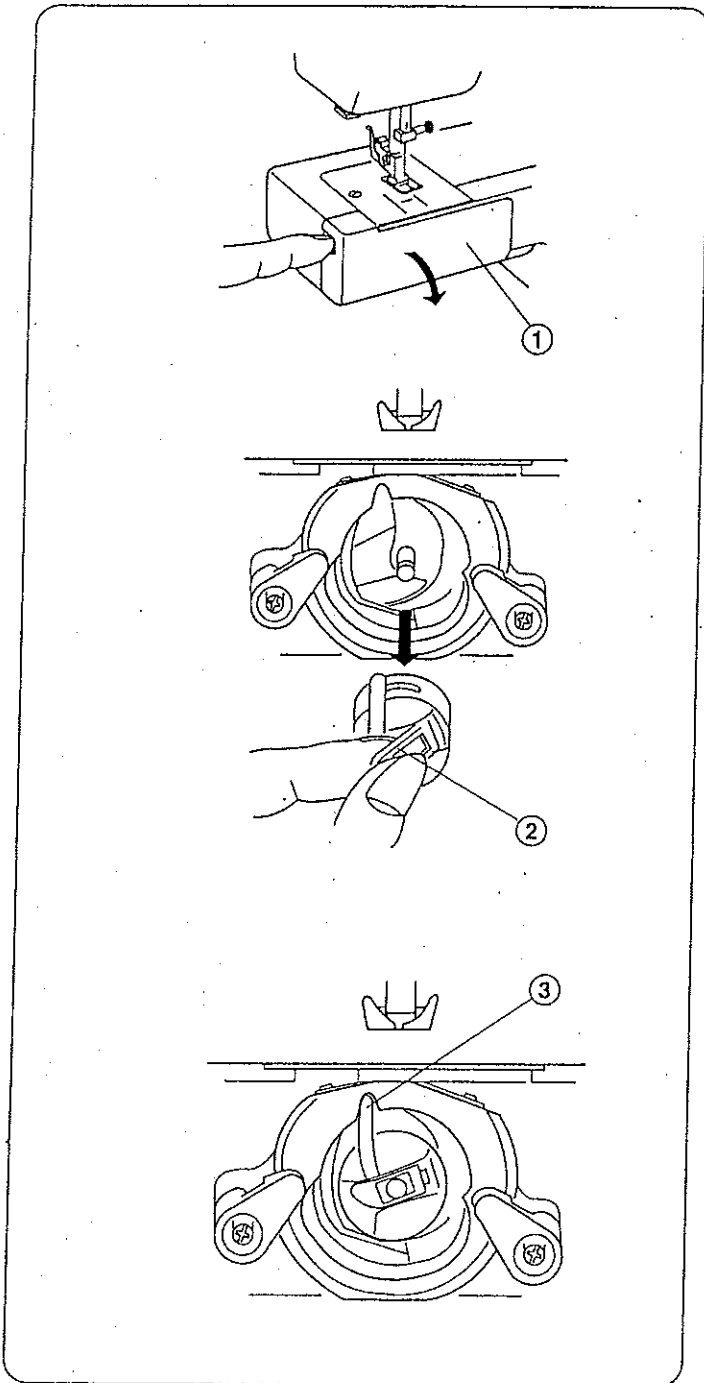

### Removing or Inserting the Bobbin Case

Open the hook cover.

- ① Hook cover

Raise the needle by turning the handwheel toward you. Take out the bobbin case by holding the latch.

- ② Latch

When inserting the bobbin case, place the horn into the recess of the hook race.

- ③ Horn

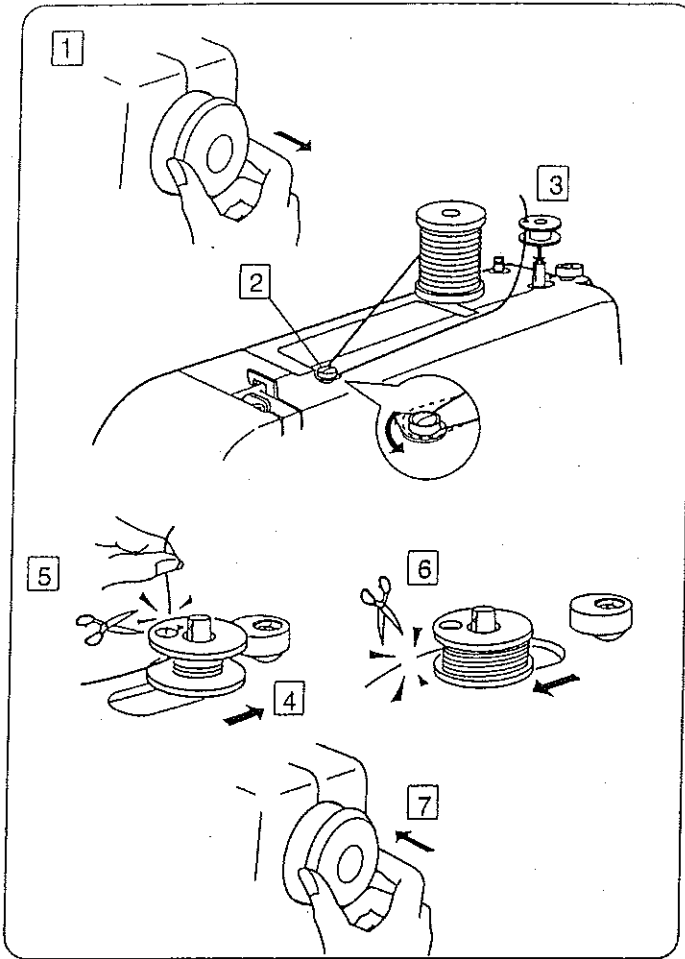

## Winding the Bobbin

- 1 Pull the handwheel out.
- 2 Draw the thread from spool. Guide the thread around the bobbin winder thread guide.
- 3 Insert the thread through the hole in the bobbin from the inside to the outside. Put the bobbin on the bobbin winder spindle.
- 4 Push it to the right.
- 5 With the free end of the thread held in your hand, depress the foot control. Stop the machine when it has made a few turns, and cut the thread close to the hole in the bobbin.
- 6 Depress the foot control again. When the bobbin is fully wound, stop the machine. Return the bobbin winder spindle to its original position by moving the spindle to the left, and cut the thread.
- 7 Push the handwheel to the left. (original position).

**Note :** Return the bobbin winder spindle when the machine stops.

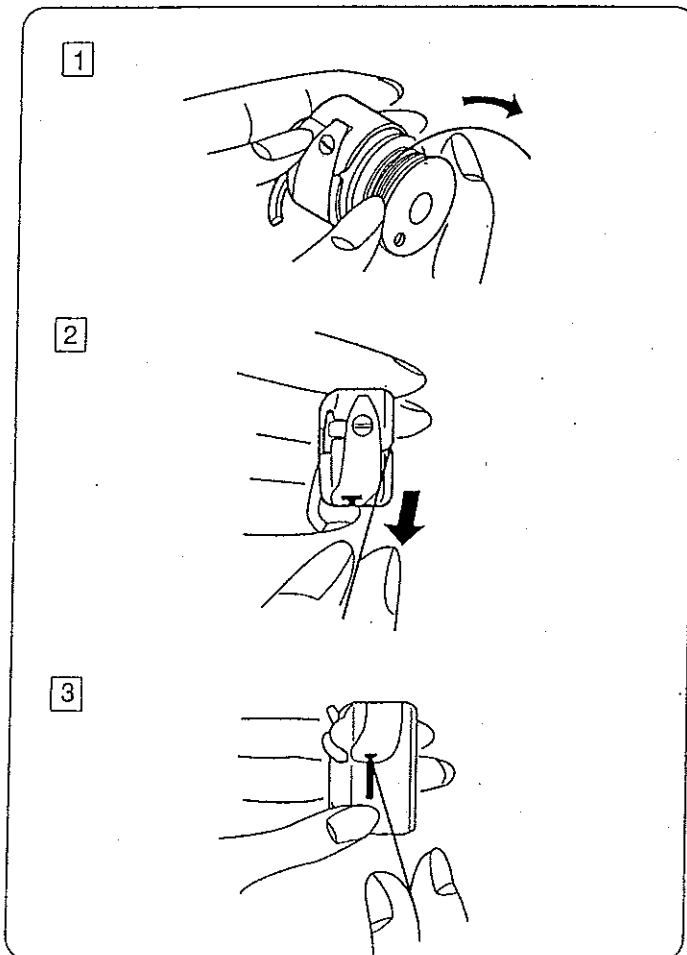

## Threading Bobbin Case

- 1 Place the bobbin into the bobbin case. Make sure the thread unwinds in the direction of arrow.
- 2 Pull the thread into the bobbin case slot.
- 3 Draw the thread under the tension spring and into the delivery eye.

\* Leave about 10 cm (4") of free thread.

## Threading the Machine

Raise the take-up lever to its highest position by turning the handwheel toward you.

Raise the presser foot.

Place a spool on the spool pin as shown, with thread coming from back of the spool.

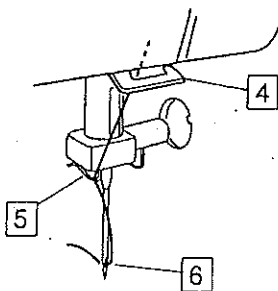
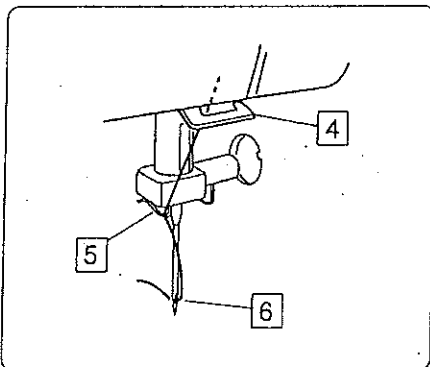
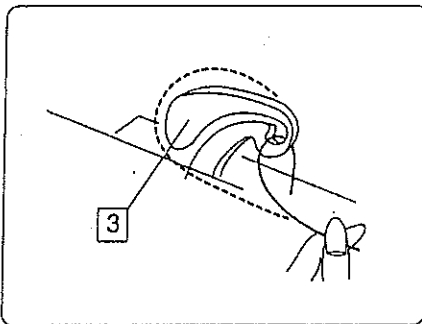
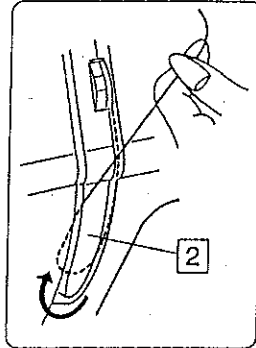
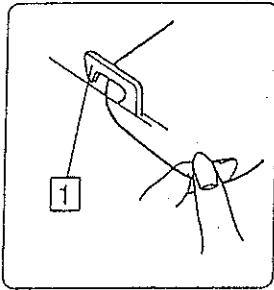
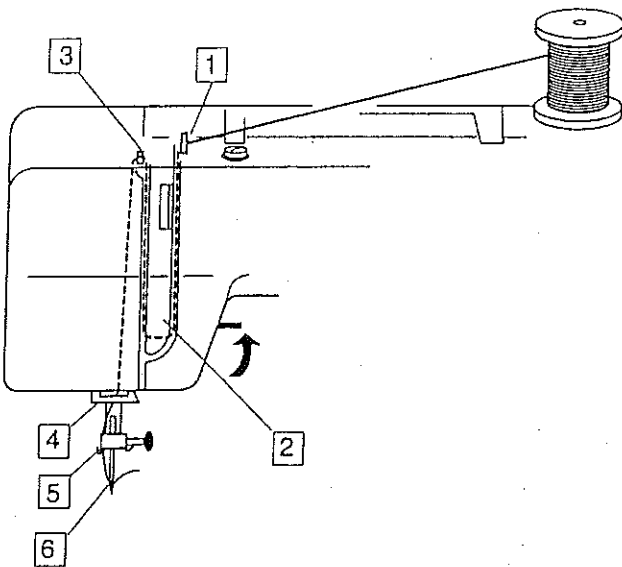

**1** Draw the thread into thread guide using both hands.

**2** While holding the thread near spool, draw thread down into the tension area and then around the check spring holder.

**3** Firmly draw the thread up and through the take-up lever from right to left.

**4** Then draw the thread down and slip it into the lower thread guide.

**5** Draw the thread down and slip it into needle bar thread guide on the left.

**6** Thread the needle eye from front to back.

\* Refer to page 10 for the built-in needle threader.

**Note :** You may want to cut the end of thread with sharp scissors for easier needle threading.

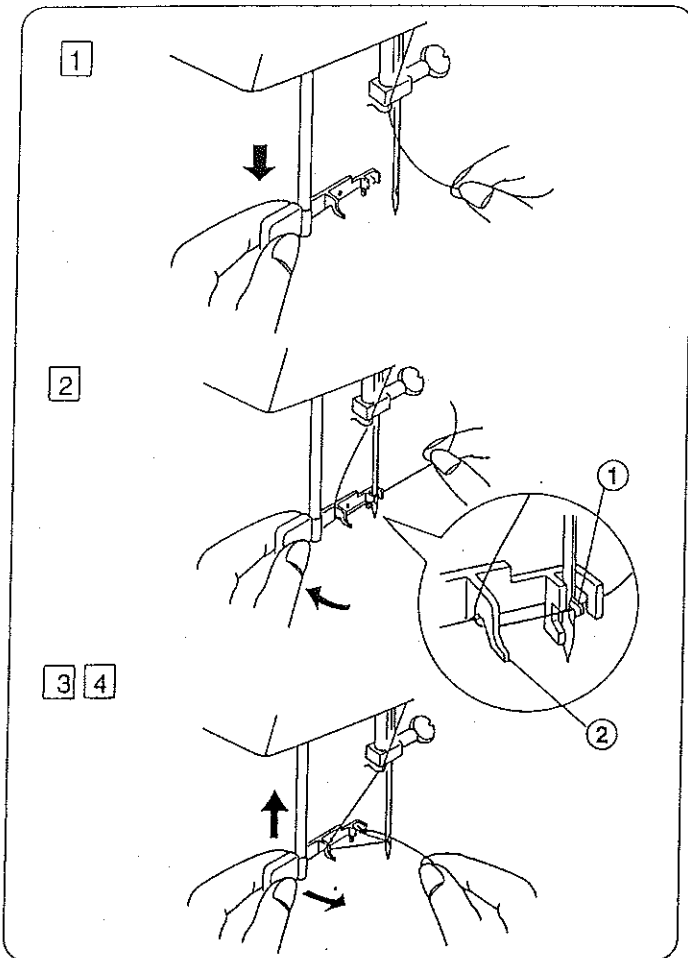

### Needle Threader

- 1 Raise the needle to its highest position.  
Pull down the needle threader knob as far as it will go.
- 2 Turn the knob in the direction of the arrow in the illustration, then insert the Hook into the needle eye. Lead the thread around the Guide and under the Hook.
  - ① Hook
  - ② Guide
- 3 Turn the knob in the direction of the arrow in the illustration, drawing the thread loop through the needle.
- 4 Pull the thread through the needle eye.

\* The needle threader can be used with a #11 to #16 needle or a Janome Blue tipped needle. Thread size 50 to 90 should also work well.

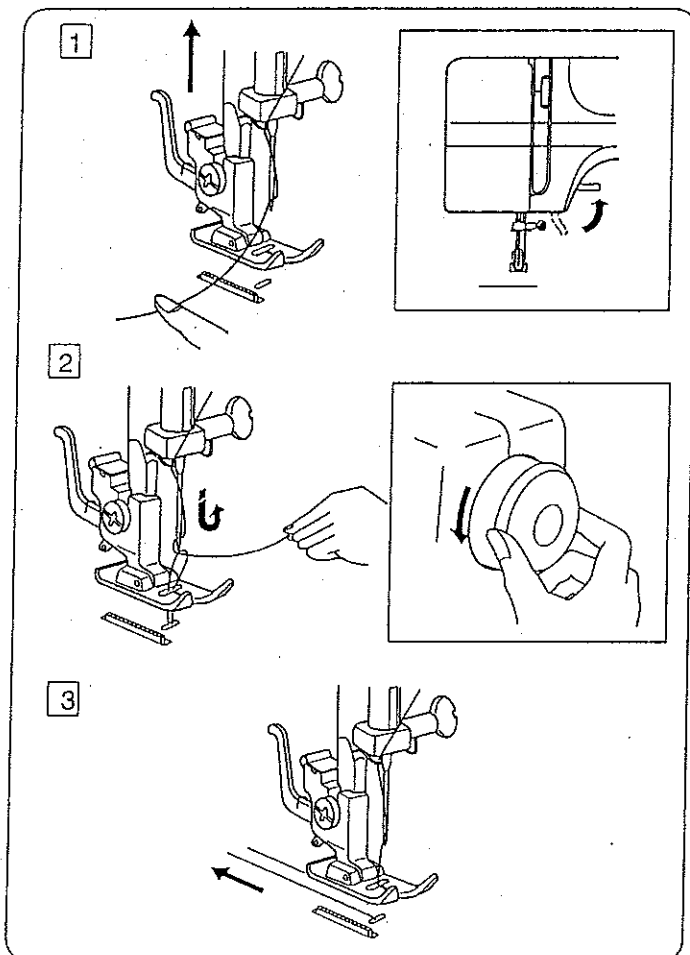

### Drawing Up Bobbin Thread

- 1 Raise the presser foot and hold the needle thread lightly with your left hand.
- 2 Turn the handwheel slowly toward you with your right hand until the needle goes down and continue turning the handwheel until the take-up lever is at its highest position. Lightly draw up the needle thread forming a loop of the bobbin thread.
- 3 Pull 15 cm (6") of both threads back and under the presser foot.

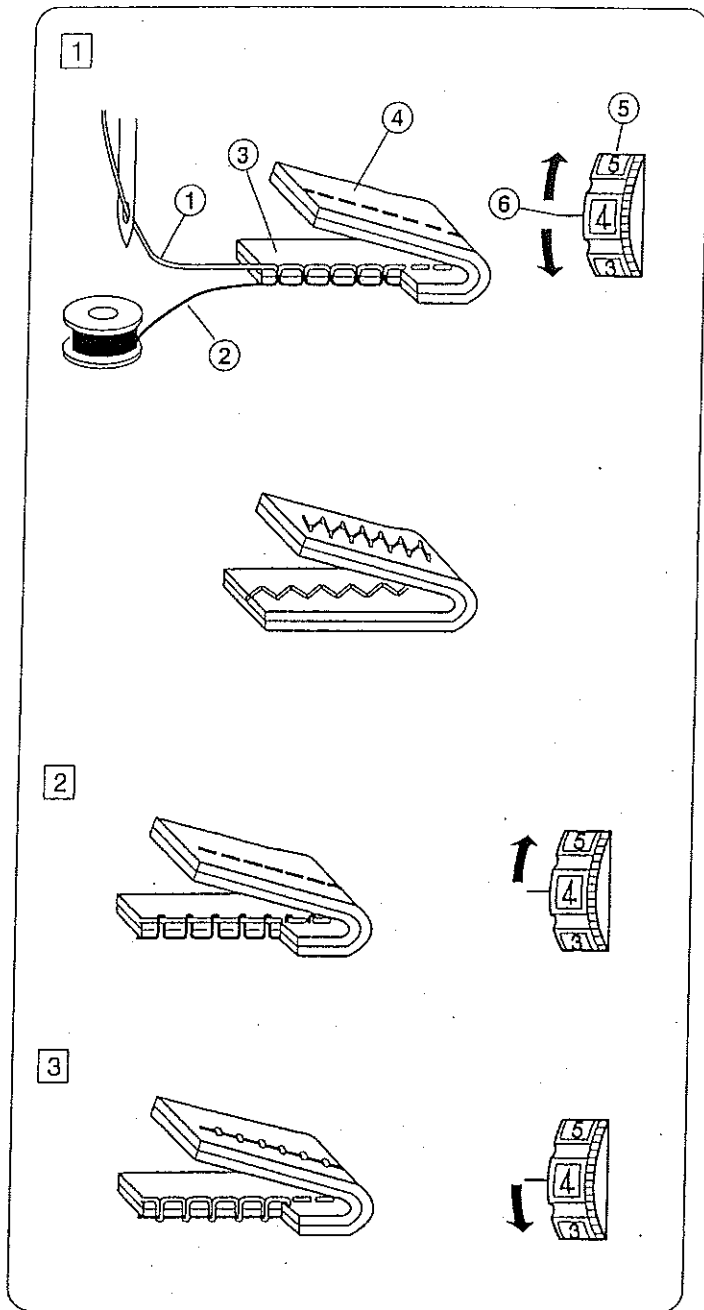

## Balancing Needle Thread Tension

**1 Correct tension**  
The thread tension is adjusted depending on the sewing materials, layers of fabric and sewing method.

- \* The ideal straight stitch has threads locked between two layers of fabric, as illustrated (magnifies to show detail).
- \* For an ideal zigzag stitch, the bobbin thread does not show on the right side (top side) of the fabric, and the needle thread shows slightly on the wrong side (bottomside) of the fabric.

- ① Needle thread (Top thread)
- ② Bobbin thread (Bottom thread)
- ③ Right side (Top side) of fabric
- ④ Wrong side (Bottom side) of fabric
- ⑤ Thread tension dial
- ⑥ Setting mark

**2 Needle thread tension is too tight**  
The bobbin thread (bottom thread) will appear on the right side (top side) of the fabric.....Loosen the needle thread tension by moving the dial to a lower number.

**3 Needle thread tension is too loose**  
The needle thread (top thread) will appear on the wrong side (bottom side) of the fabric.....Tighten the needle thread tension by moving the dial to a higher number.

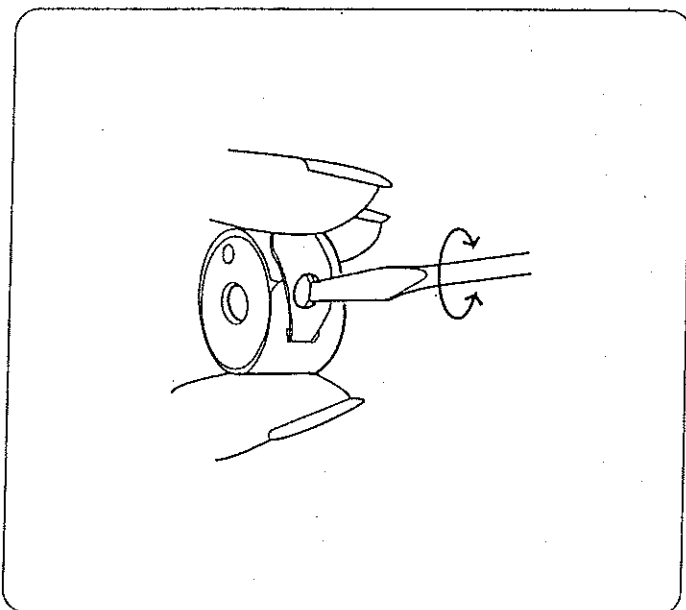

## Adjusting Bobbin Thread Tension

For general sewing, the bobbin thread tension does not need to adjust. However, you can adjust the bobbin thread tension for a specific sewing need.

Turn the adjusting screw to the right to tighten or, to the left to loosen the tension.

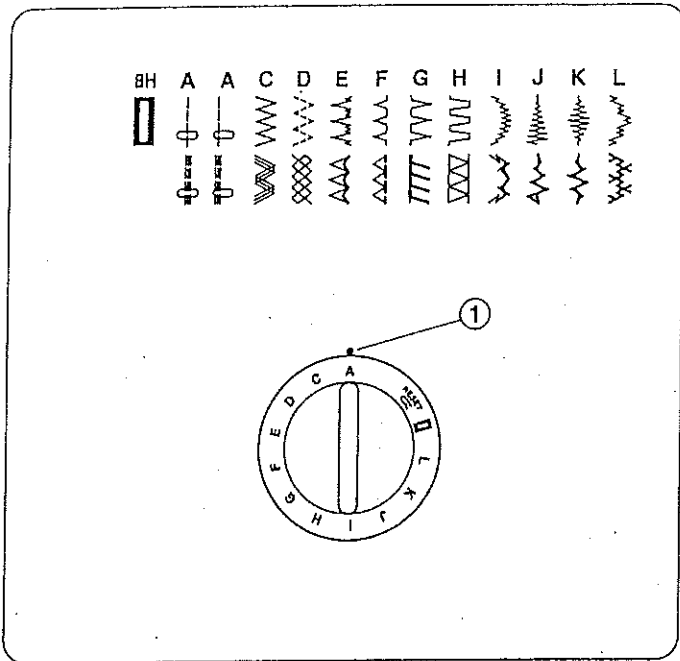

### Pattern Selector Dial

Raise the needle and presser foot. Turn the pattern selector dial to set the symbol corresponding to the desired pattern at the setting mark.

① Setting mark

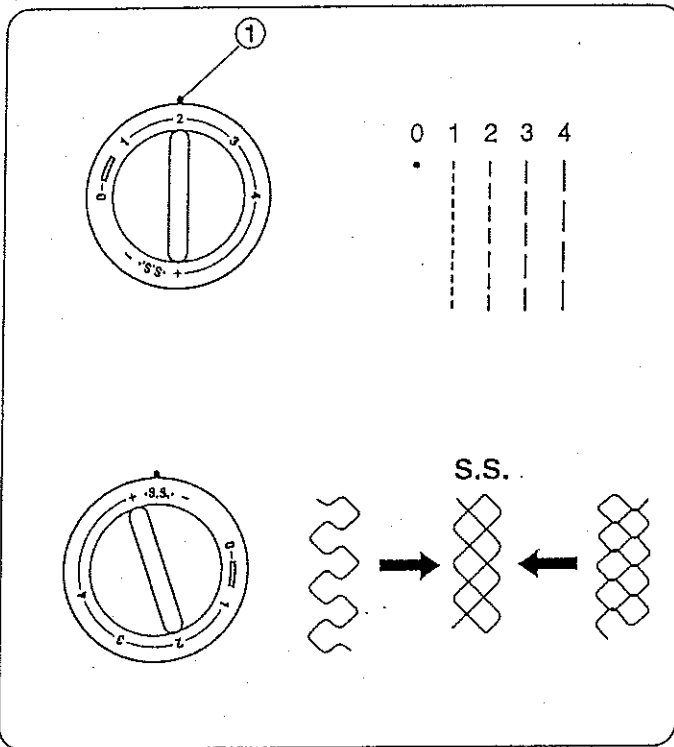

### Stitch Length Dial

Turn the stitch length dial to set the desired stitch length at the setting mark.

The higher the number, the longer the stitch length

① Setting mark

- "  " is the recommended setting for buttonhole stitching.
- Adjust the dial in the 0.5–4 range when you sew the zigzag stitch.
- Set the dial at "S.S." to sew the stretch stitch pattern.
- If the stretch stitch pattern is not even, turn the stitch length dial in toward "-" to compress it, or "+" to expand it.

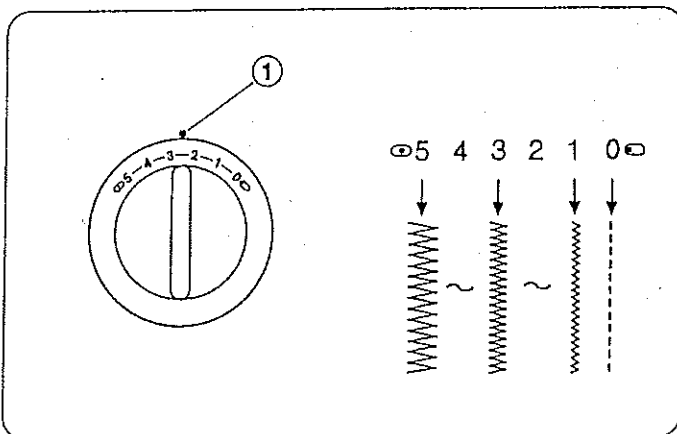

### Stitch Width Dial

Turn the stitch width dial to set the desired stitch width at the setting mark.

The higher the number, the wider the stitch width

① Setting mark

**Note :** Raise the needle above the fabric, when you turn the stitch width dial.

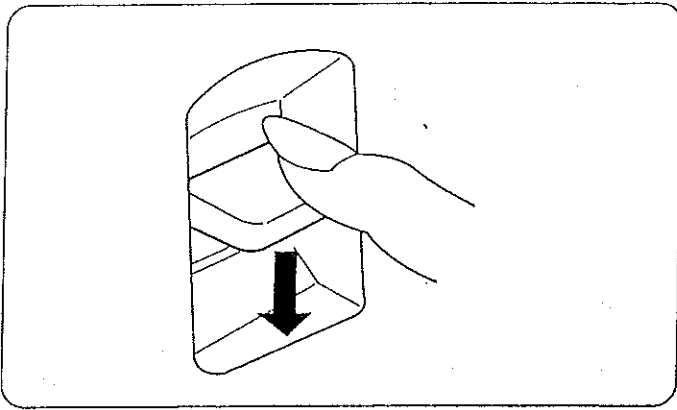

### Reverse Stitch Button

As long as you keep the reverse stitch button depressed, the machine sews backwards.

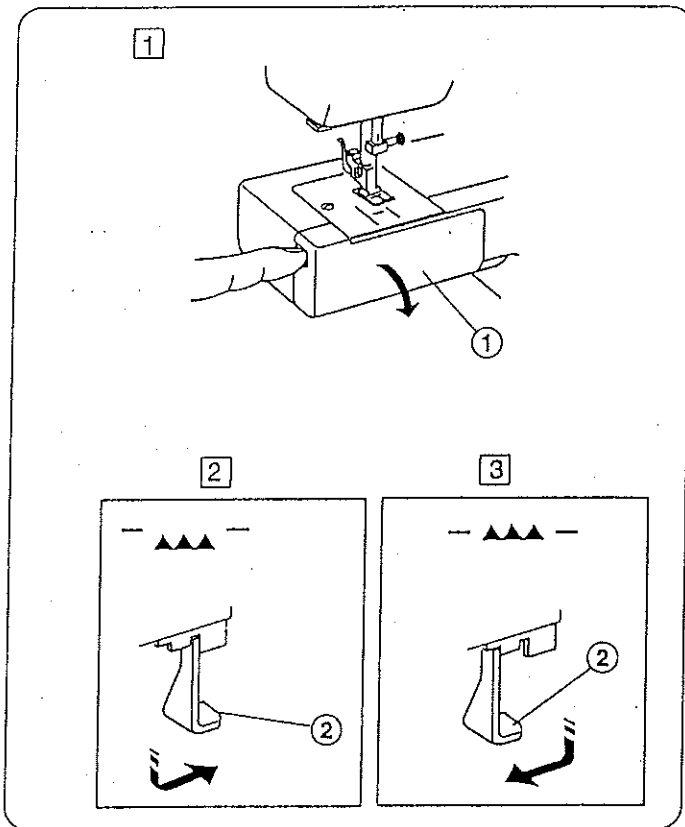

### Dropping the Feed Dog

**1** Open the hook cover.

① Hook cover

**2** To drop the feed dog, pull down the drop lever and move it to the right, as illustrated.

② Drop lever

**3** To raise the feed dog, pull down the drop lever and move it to the left, as illustrated.

\* The feed dog must be up for normal sewing.

\* The feed dog will return to the up position when the machine starts running.

## SECTION 3. BASIC SEWING

### Straight Stitch Sewing

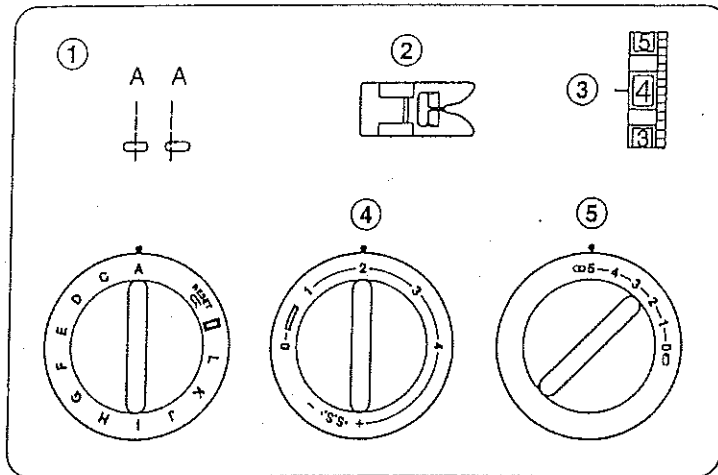

- ① Pattern selector: A
- ② Presser foot: Zigzag foot
- ③ Thread tension: 2-6
- ④ Stitch length: 1.5-4
- ⑤ Stitch width: ∞ (0) or ∞ (5)

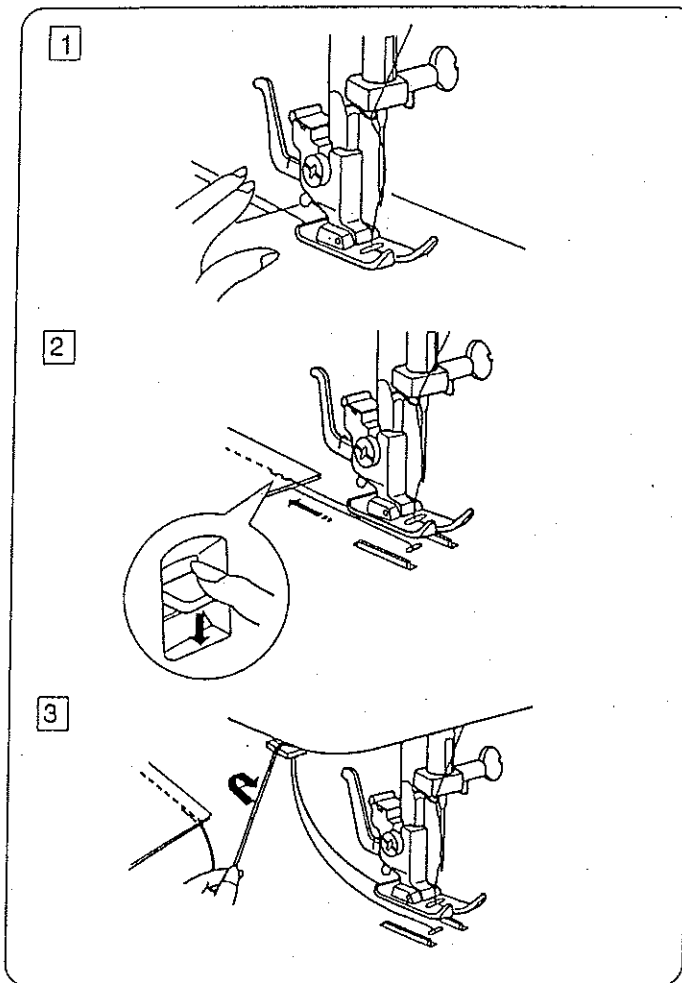

- 1 Raise the presser foot and position the fabric with its edge lining up with a seam guide line on the needle plate.  
Lower the needle into the fabric.  
Lower the presser foot and smooth the threads toward the back. Depress the foot control.  
Gently guide the fabric along the guide line letting the fabric feed by itself.
- 2 For fastening the end of seams, press the reverse stitch button and sew several reverse stitches.  
Raise the presser foot and remove the fabric, drawing the threads to the back.
- 3 Draw the threads up and into the thread cutter.  
The threads are cut the proper length for starting the next seam.

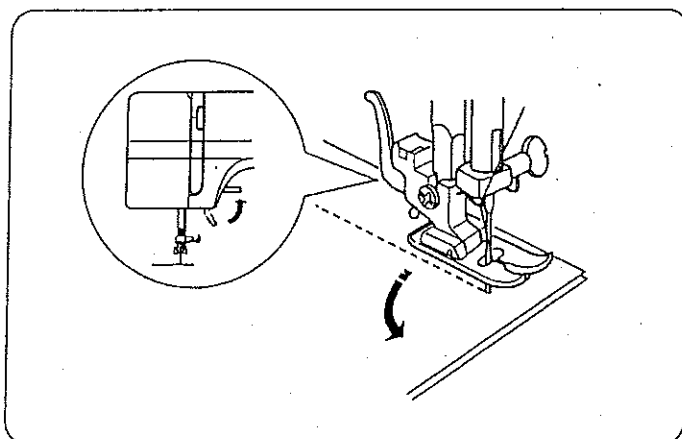

### To Change Sewing Direction

- Stop the machine and turn the handwheel toward you to bring the needle down into the fabric.
- Raise the presser foot.
- Pivot the fabric around the needle to change sewing direction as desired. Lower the presser foot and continue sewing.



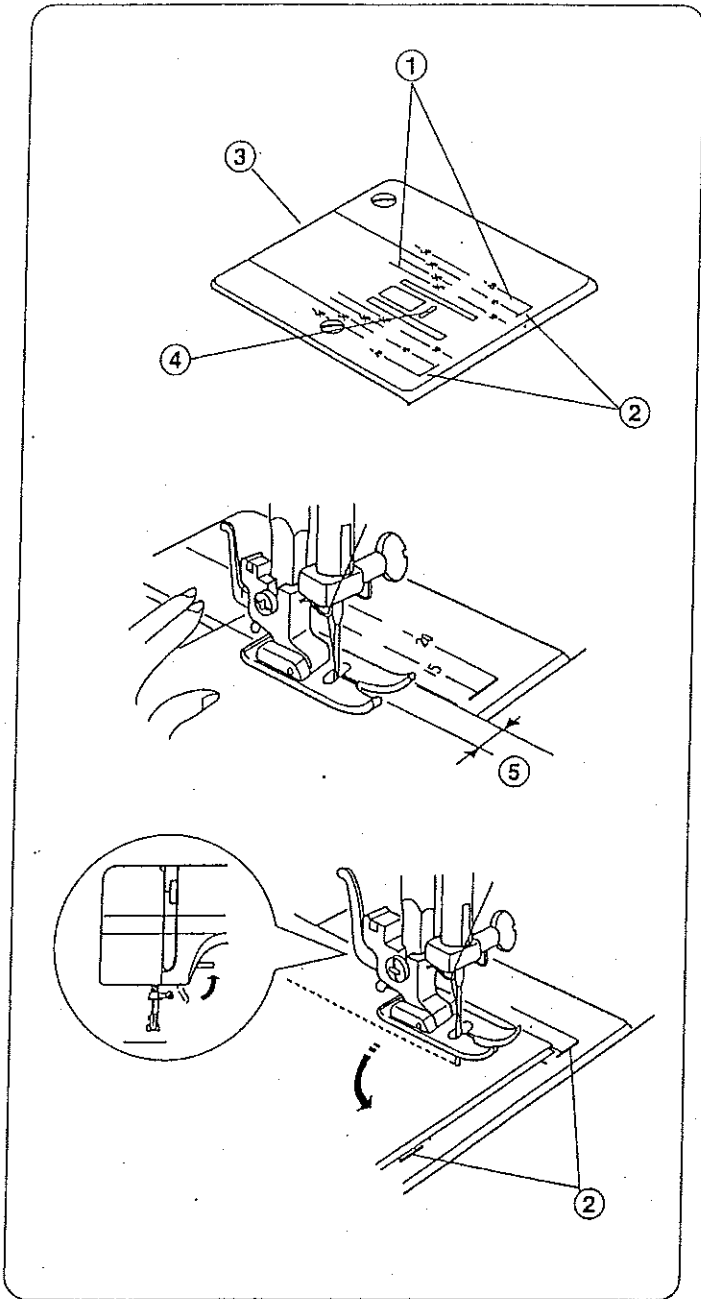

### Using the Seam Guides on the Needle Plate

The seam guides on the needle plate help you to measure seam width.

\* The numbers indicate the distance between the centre needle position and the guide line.

Numbers on the needle plate	10	15	20	3/8"	4/8"	5/8"	6/8"
Distance in centimeters	1.0	1.5	2.0	1.0	1.3	1.6	1.9

- ① Guide lines
- ② Cornering guide
- ③ Needle plate
- ④ Needle plate hole
- ⑤ Seam width from the center needle position

### Turning Square Corners

To turn a square corner 1.6 cm (5/8") from the fabric edge. When the fabric edge facing you lines up with the cornering guide as illustrated, stop stitching and lower the needle by turning the handwheel towards you.

Raise the presser foot and turn the fabric to line the edge with the 1.6 cm (5/8") seam guide.

Lower the presser foot and begin stitching in the new direction.

- ② Cornering guide

### Variable Needle Position

When the straight stitch (pattern A) is selected, you can move the needle between center and left needle position by turning the stitch width dial.

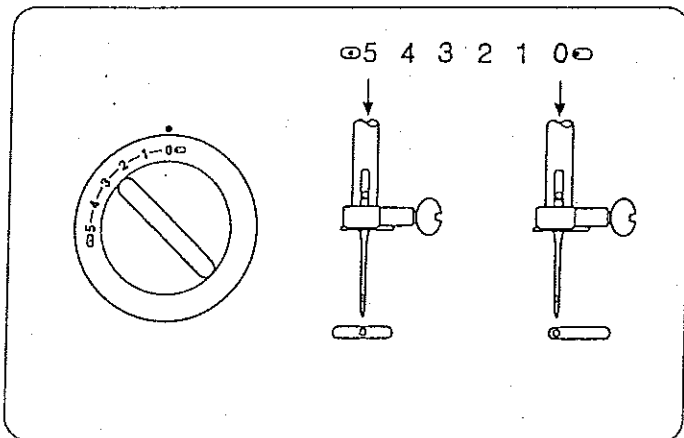

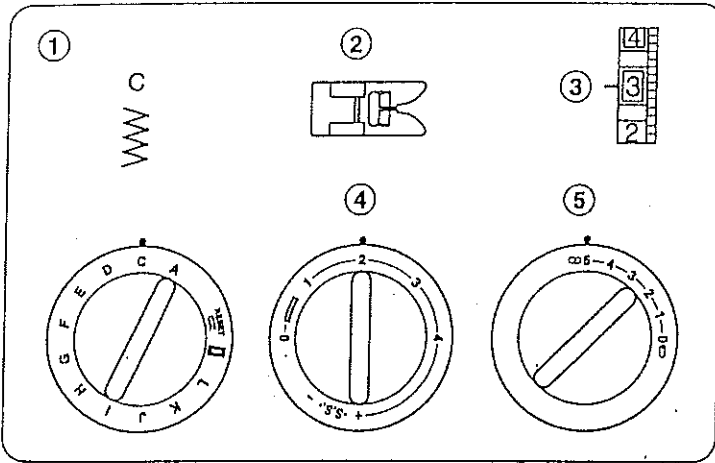

## Zigzag Stitching

- ① Pattern selector: C
- ② Presser foot: Zigzag foot
- ③ Thread tension: 2-5
- ④ Stitch length: 0.5-4
- ⑤ Stitch width: 1-5

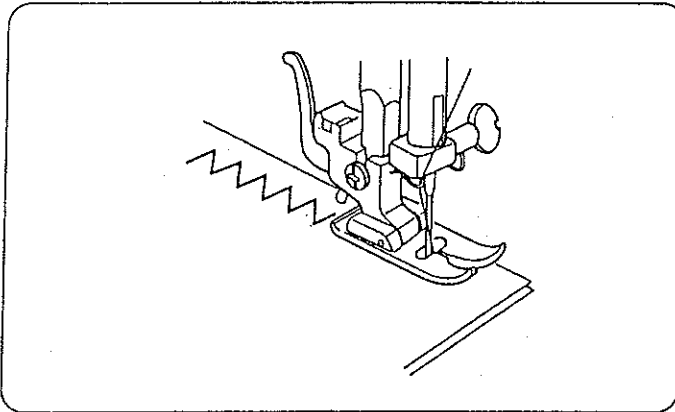

Simple zigzag stitching is widely used for overcasting, sewing on buttons etc.

## SECTION 4. UTILITY STITCHING

### Overcasting

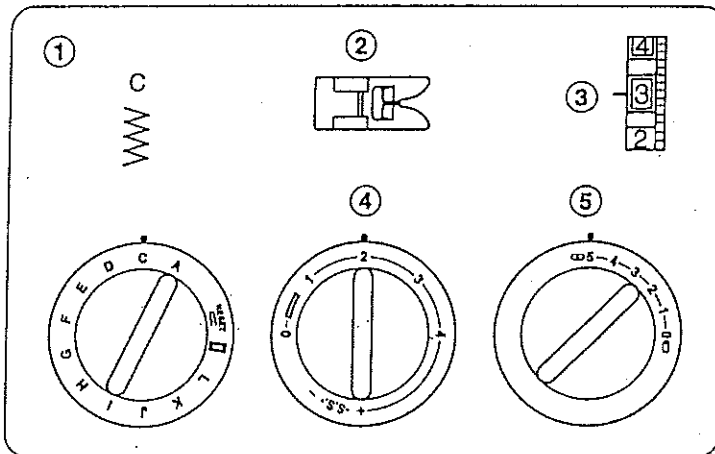

- ① Pattern selector: C
- ② Presser foot: Zigzag foot
- ③ Thread tension: 1-4
- ④ Stitch length: 1-2
- ⑤ Stitch width: 5

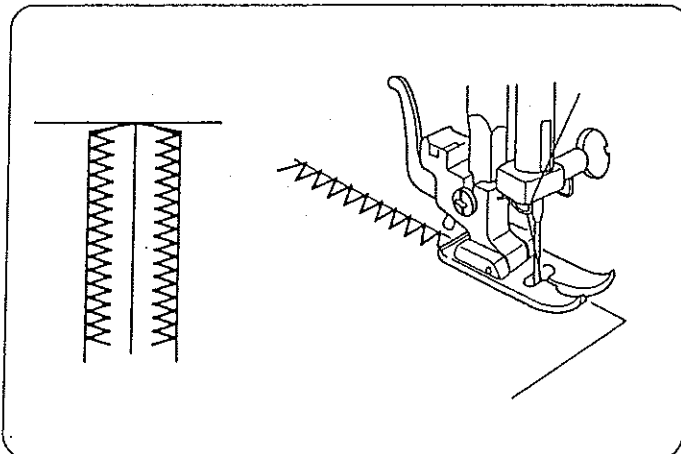

The zigzag stitch is used on the seam allowance to prevent fabric from fraying at raw edges.

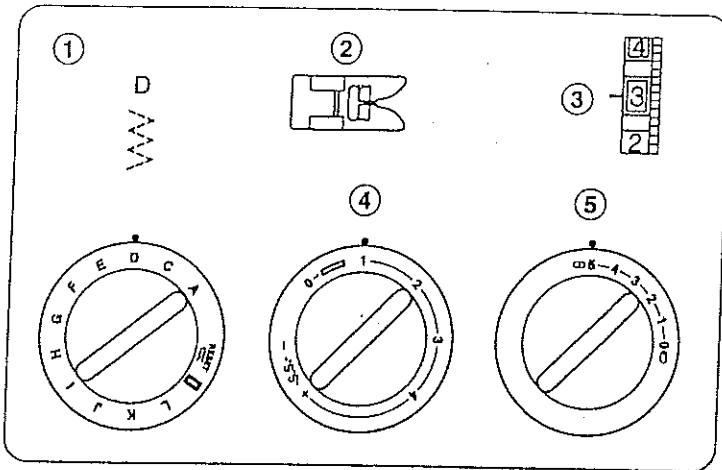

### Tricot Stitch

- ① Pattern selector: D
- ② Presser foot: Zigzag foot
- ③ Thread tension: 1-4
- ④ Stitch length: 0.5-1.5
- ⑤ Stitch width: 5

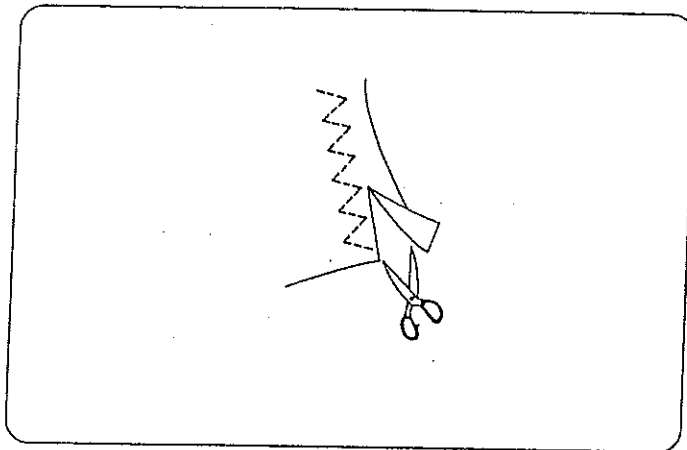

This stitch is used to finish the seam allowance on synthetics and other fabrics that tend to pucker. Place your fabric to allow a 1.6 cm (5/8") seam. Trim the seam allowance after sewing.

**Note :** Be careful not to cut the stitches.

It is also handy for darning and mending tears.

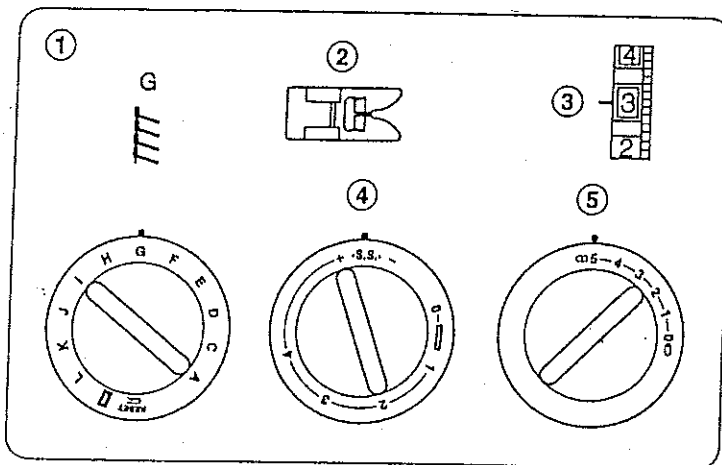

### Knit Stitch

- ① Pattern selector: G
- ② Presser foot: Zigzag foot
- ③ Thread tension: 1-4
- ④ Stitch length: S.S.
- ⑤ Stitch width: 5

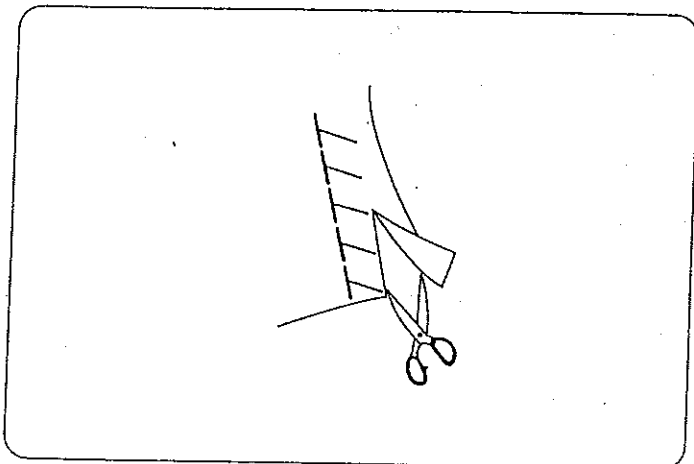

This knit stitch is ideal for sewing swimwear and stretch velour because it provides the greatest amount of elasticity and strength.

Place your fabric to allow a 1.6 cm (5/8") seam. Trim the seam allowance after sewing.

**Note :** Be careful not to cut the stitches.

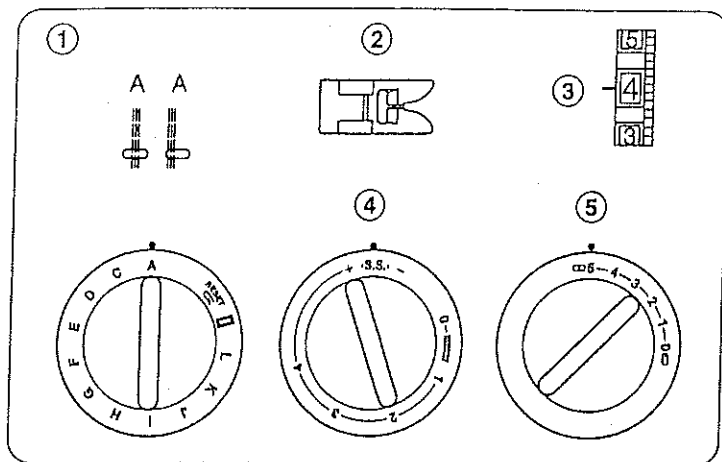

### Straight Stretch Stitch

- ① Pattern selector: A
- ② Presser foot: Zigzag foot
- ③ Thread tension: 2-6
- ④ Stitch length: S.S.
- ⑤ Stitch width: ∞ (0) or ∞ (5)

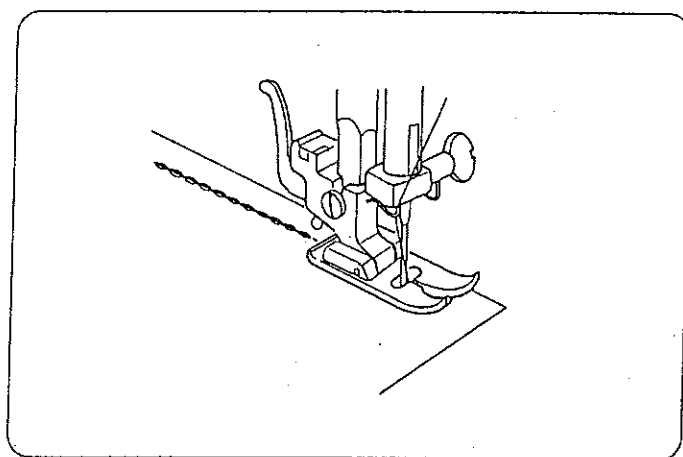

The stitch is sewn with two stitches forward and one stitch backward forming a seam that does not rip easily.

## Sewing on Buttons

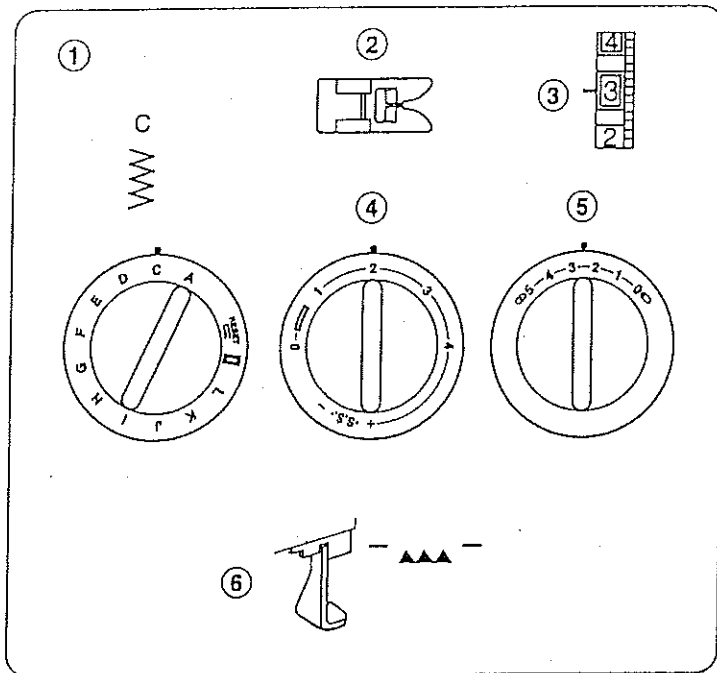

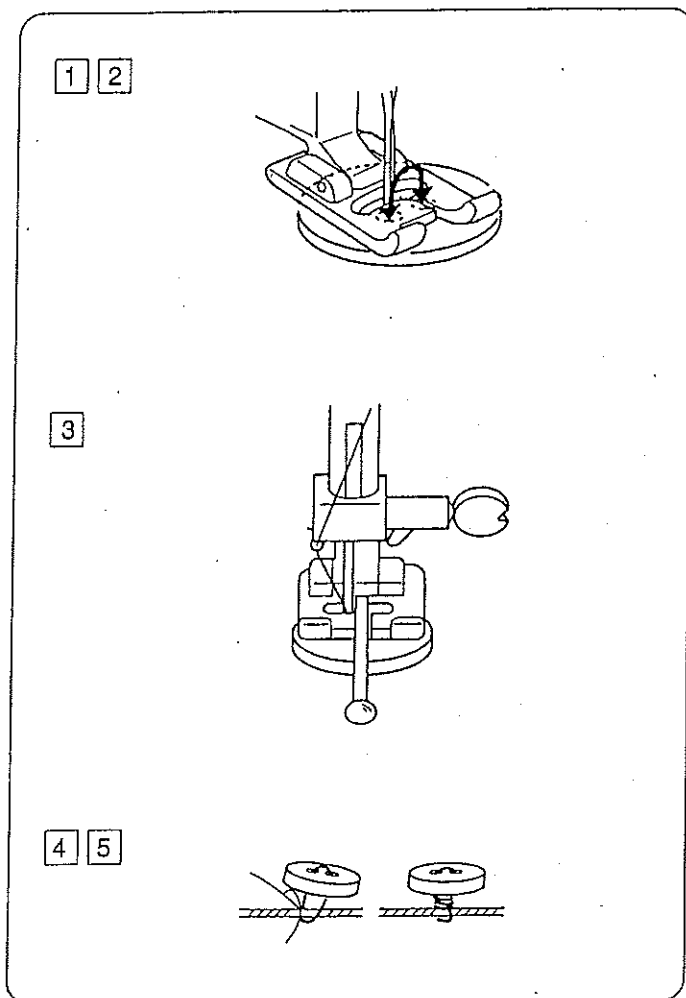

- ① Pattern selector: C
- ② Presser foot: Zigzag foot
- ③ Thread tension: 1-3
- ④ Stitch length: Any
- ⑤ Stitch width: Adjust as necessary
- ⑥ Feed dog: Lowered

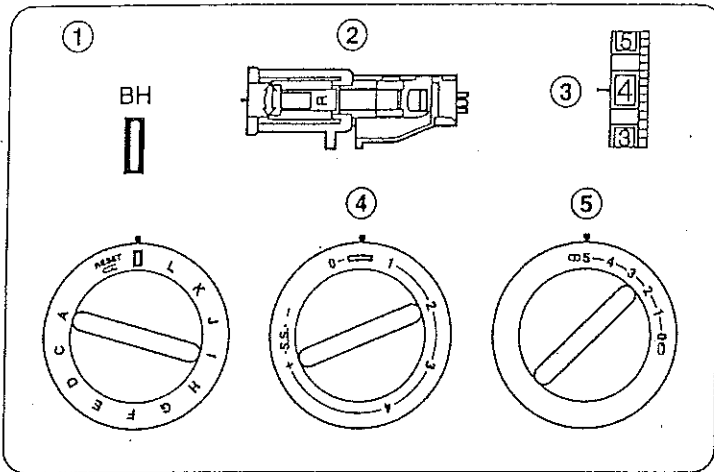

- 1 Adjust the stitch width, and turn the handwheel to check if the needle enters into each hole in the button.
- 2 Lower the foot to hold the button in place. The holes in the button should align with the slot of the foot.
- 3 A pin can be placed on the foot to form a shank. Make sure to check if the needle enters into both holes on the button. Sew about 10 stitches and cut the needle and bobbin threads, leaving 20cm (8") tail.
- 4 Bring the needle threads between the button and fabric through the holes on the button. Pull the needle threads to pick bobbin threads up to the right side of the fabric. Wind the threads to form a shank and tie them together.
- 5 Raise the feed dog after sewing.



## Buttonhole

- |   |                   |  |
|---|-------------------|--|
| ① | Pattern selector: |  (BH)     |
| ② | Presser foot:     | Automatic buttonhole foot  |
| ③ | Thread tension:   | 1-5  |
| ④ | Stitch length:    |  (0.5 -1) |
| ⑤ | Stitch width:     | 5  |

- \* The size of buttonhole is automatically set by placing the button in the automatic buttonhole foot.
- \* The button holder of the foot takes a button size up to 2.5 cm (1") in diameter.
- \* Make a test buttonhole on a sample duplicating the fabric, interfacing and seams of the actual garment.
- \* Place the button on the fabric sample and mark the top and bottom to determine the position of buttonhole.
- \* Use interfacing on stretch fabrics.

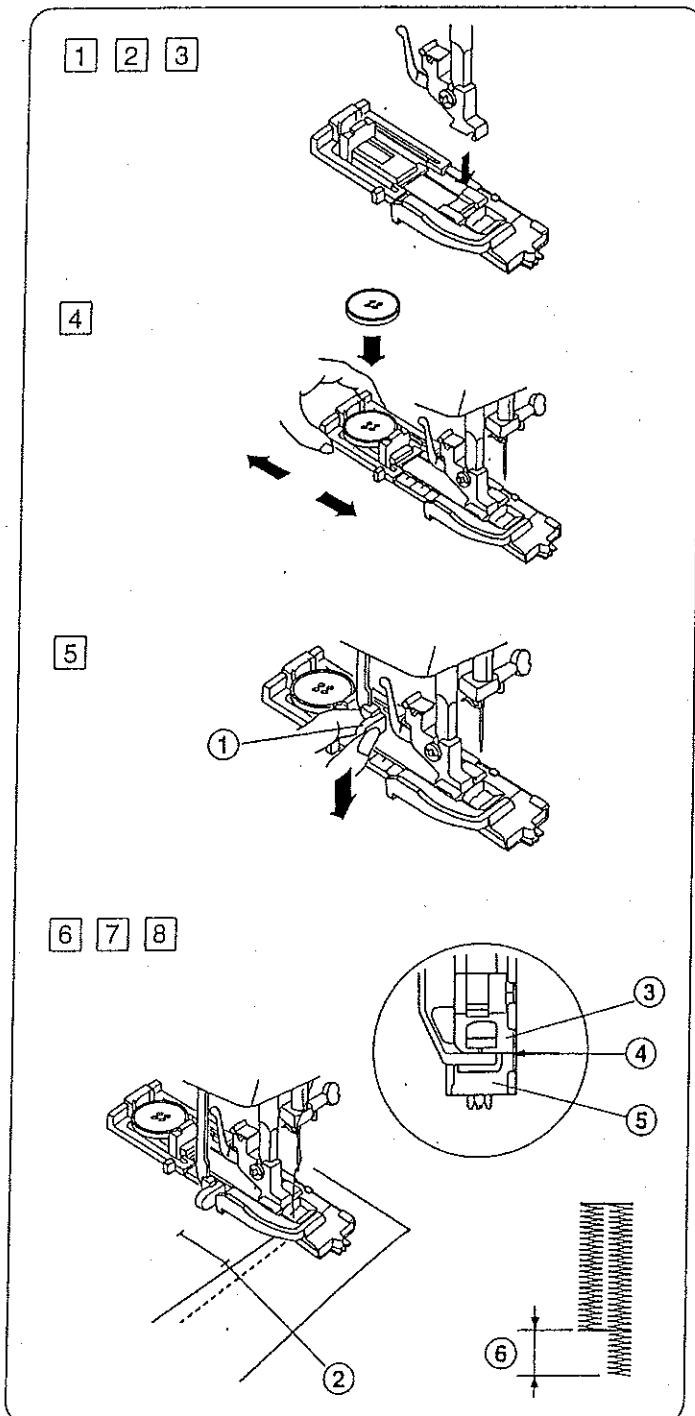

- 1 Turn the handwheel toward you to raise the needle to its highest position.  
Raise the presser foot lifter.
- 2 Select the pattern "BH" by turning the pattern selector dial.  
If the BH pattern is already selected, reset the dial once according to the procedure in 12.
- 3 Attach the automatic buttonhole foot.
- 4 Pull the button holder to the back, and place the button in it. Push back the button holder toward you as far as it will go.
- 5 Pull the buttonhole lever downward as far as it will go.  
① Buttonhole lever
- 6 Insert fabric under the foot.  
Turn the handwheel slowly towards you with your right hand until the needle goes down and continue turning handwheel until the take-up lever is at its highest position.
- 7 Remove the fabric to the left to draw both threads to the left.
- 8 Insert the garment under the foot, and lower the needle at the starting point.  
Then lower the automatic buttonhole foot.

**Note :** Make sure there is no gap between the slider and the spring holder. If there is a gap, the length of the rows will be different, as shown.

- ② Starting point
- ③ Slider
- ④ There should be no gap
- ⑤ Spring holder
- ⑥ Difference

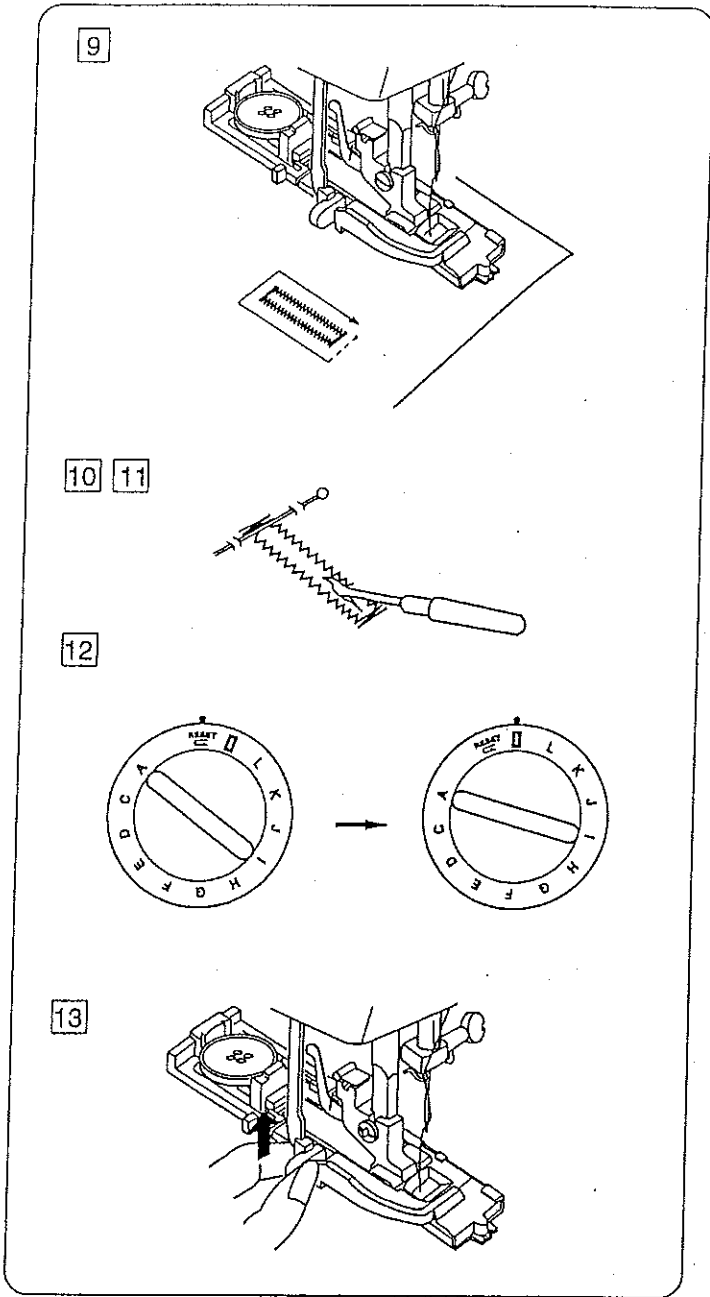

- 9 Sew slowly and stop the machine when a buttonhole is completed.
  - The machine sews the front bartack and left row first, then the back bartack and right row.
- 10 Cut both needle and bobbin threads leaving about 10 cm (4") thread ends. Draw the needle thread to wrong side of fabric by pulling the bobbin thread. Then, knot the threads.
- 11 Insert a pin inside the bartack. Then cut the opening with seam ripper. Take care not to cut the stitches.
- 12 To repeat buttonhole sewing, turn the stitch selector to **RESET**, then back to **0** again, as shown. Now, simply step on the foot control to sew an identical buttonhole.
- 13 When buttonhole sewing is finished, push the buttonhole lever upward as far as it will go.

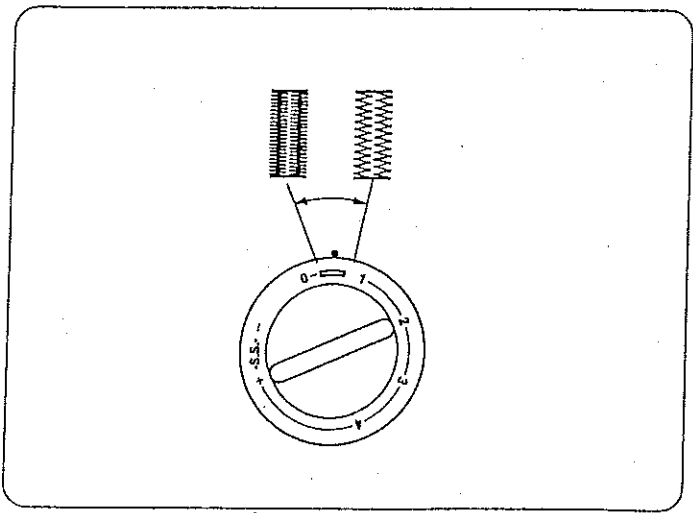

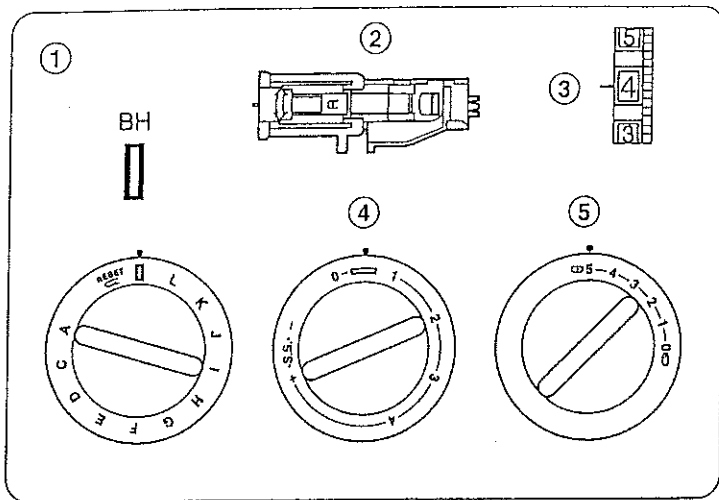

**To adjust buttonhole stitch density :**

Stitch density of buttonhole sewing should be adjusted within the mark "  " on the stitch length dial.



### Corded Buttonhole

- ① Pattern selector:  (BH)
- ② Presser foot: Automatic buttonhole foot
- ③ Thread tension: 1 - 5
- ④ Stitch length:  (0.5 - 1)
- ⑤ Stitch width: 5

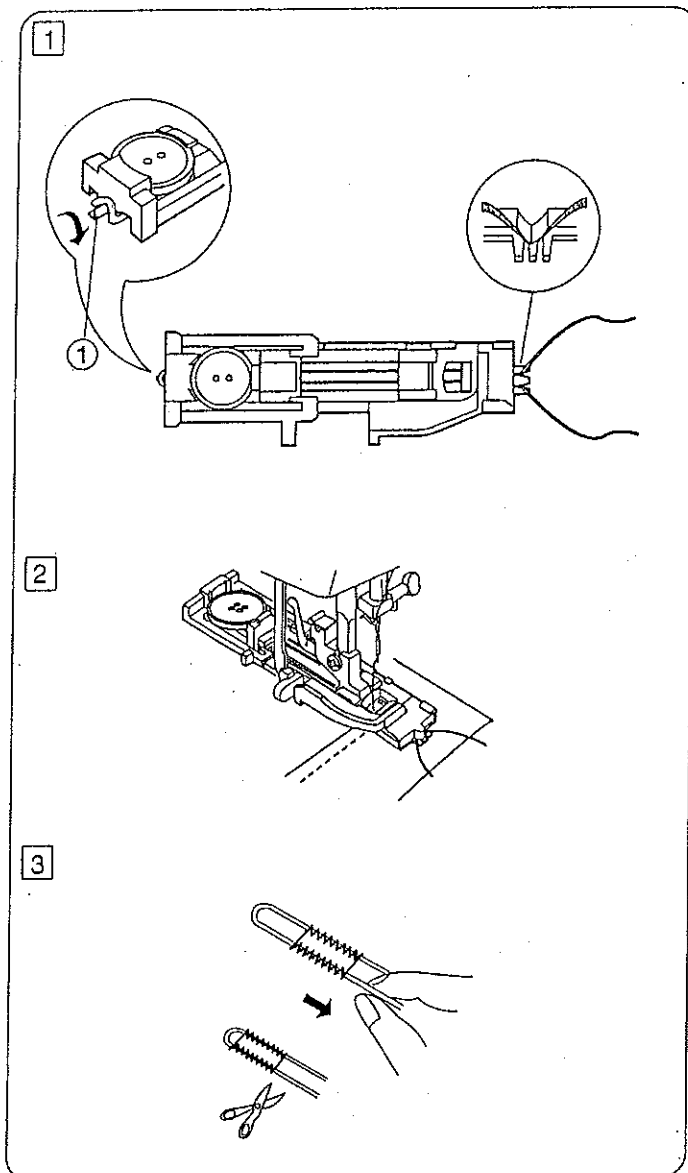

① Use the same procedure as automatic buttonhole.

- \* Set the stitch width to match with the thickness of the cord used.

With the buttonhole foot raised, hook the filler cord on the spur at the back of the buttonhole foot. Bring the ends toward you under the buttonhole foot, clearing the front end.

Hook the filler cord into the forks on the front of the automatic buttonhole foot to hold them tight. Lower the needle into the garment where the buttonhole will start and lower the foot.

① Spur

- ② Depress the foot control gently and sew the buttonhole. Each side of the buttonhole and the bartacks will be sewn over the cord. Remove the fabric from the machine and cut the sewing threads only.

- ③ Pull the left end of the filler cord to tighten it. Thread the end through a darning needle, draw to the wrong side of the fabric and cut.

- \* To cut the buttonhole opening, refer to the instructions on page 21.



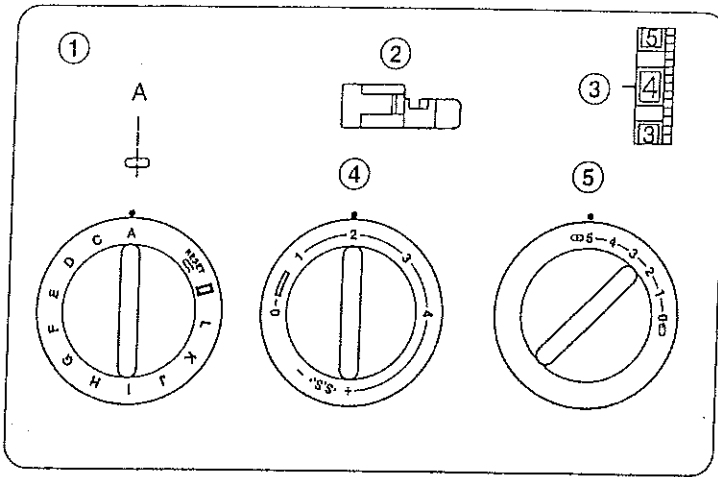

## Zipper Application

- ① Pattern selector: A
- ② Presser foot: Zipper foot
- ③ Thread tension: 3 - 6
- ④ Stitch length: 1.5 - 4
- ⑤ Stitch width: 5

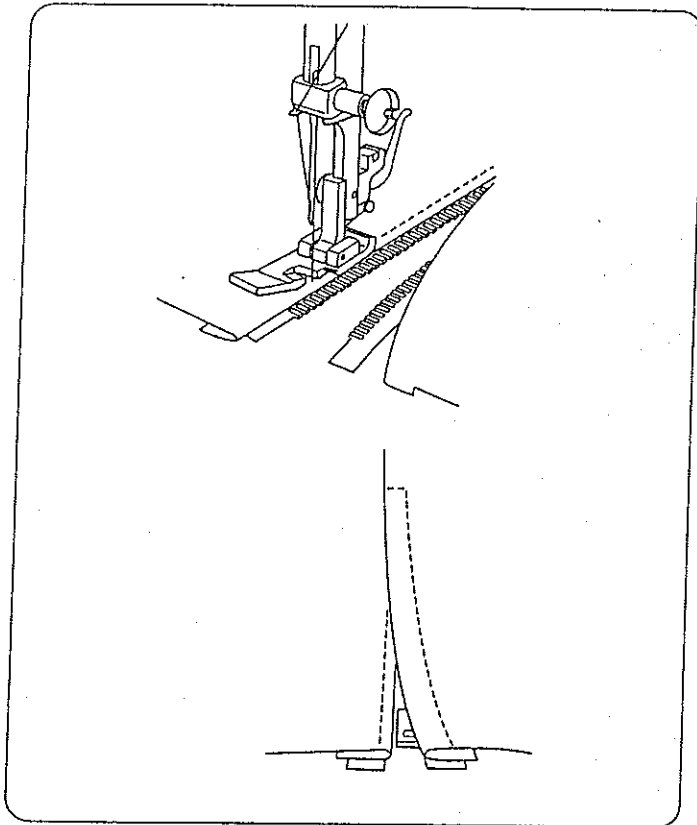

Pin or baste zipper tape to fabric and place it under the foot. Smooth the threads toward the back and lower the foot. To sew the left side of the zipper, guide the zipper teeth along the edge of the foot and stitch through the garment and zipper tape. Turn the fabric and sew the other side of the zipper in the same way as you did the left side.

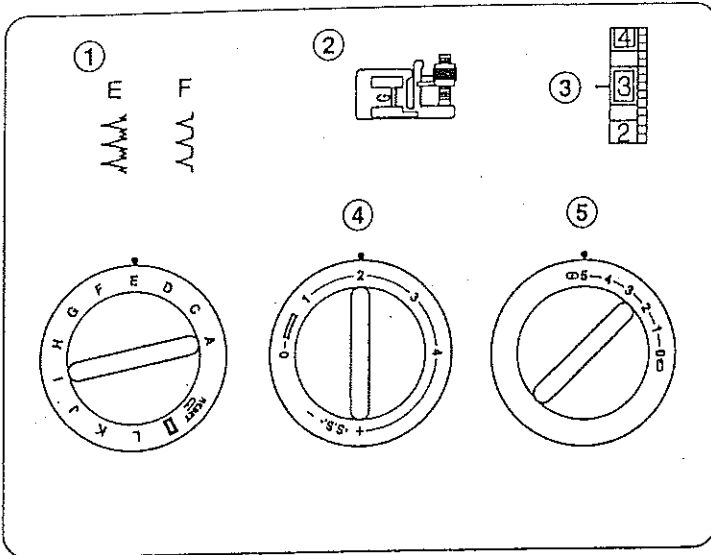

## Blind Stitch Hemming

- ① Pattern selector: E or F
- ② Presser foot: Blind hem foot
- ③ Thread tension: 2-4
- ④ Stitch length: 1-3
- ⑤ Stitch width: 5

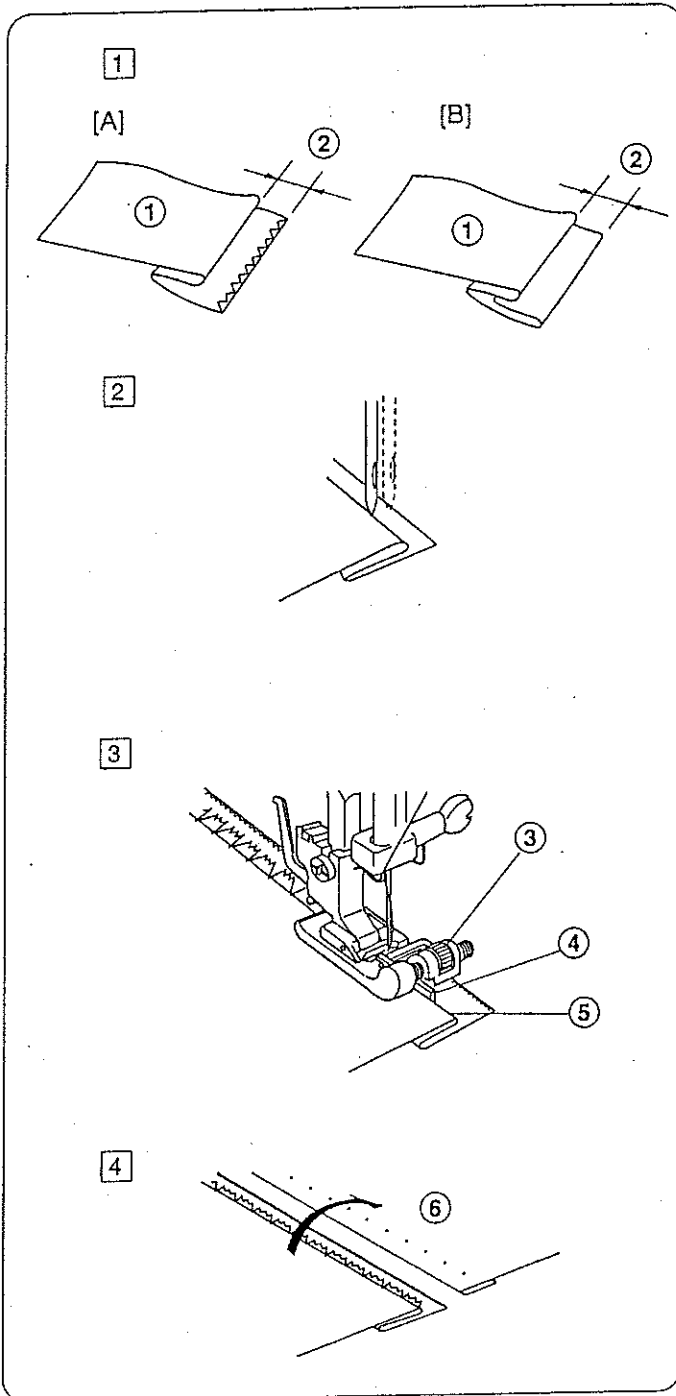

- ① Fold up the hem and fold it back to from a 0.4 to 0.7cm (1/4") allowance as illustrated.

- ① Wrong side of the fabric
- ② 0.4 to 0.7 cm (1/4")

[A] Heavy weight fabrics  
[B] Fine or medium weight fabrics

- ② Place the fabric so that the needle just pierces the folded edge when the needle comes over the extreme left side. Lower the presser foot.

- ③ Turn the guide screw to adjust the position of the guide to match it with the folded edge. Sew guiding the folded edge along the guide.

- ③ Guide screw
- ④ Guide
- ⑤ Folded edge

- ④ Open the fold flat.
- ⑥ Right side of the fabric

\* If the needle drops far left, the stitches will show on the right side of the fabric.

## SECTION 5. DECORATIVE STITCHING

### Shell Tuck

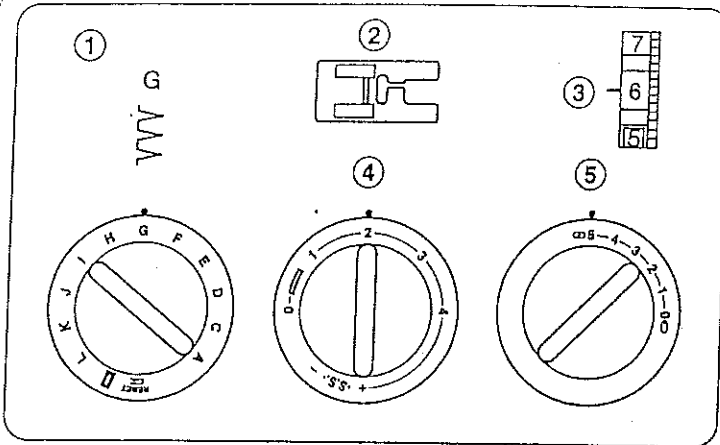

- ① Pattern selector: G
- ② Presser foot: Satin stitch foot
- ③ Thread tension: 6-8
- ④ Stitch length: 2-3
- ⑤ Stitch width: 5

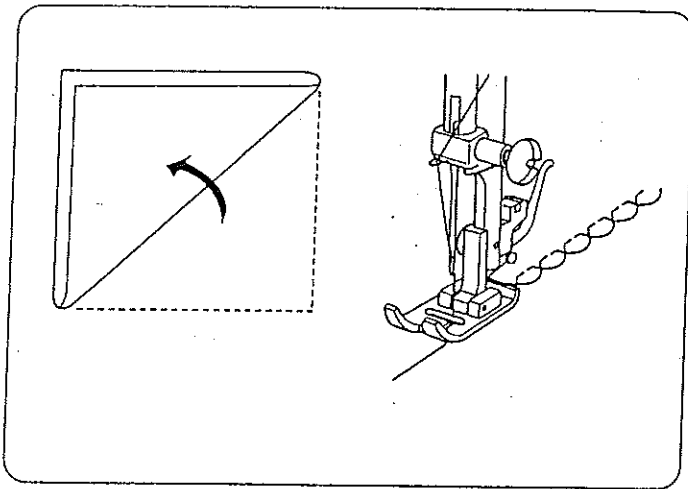

Place the folded edge along the slot of foot.  
The needle should fall off the edge of the fabric on the right forming a tuck.

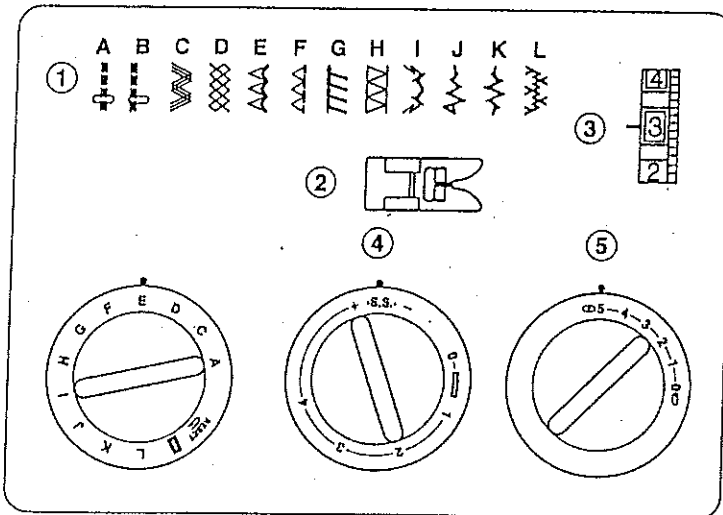

### Stretch Stitch Patterns

- ① Pattern selector: A-L
- ② Presser foot: Zigzag foot
- ③ Thread tension: 1-4
- ④ Stitch length: S.S.
- ⑤ Stitch width: 5

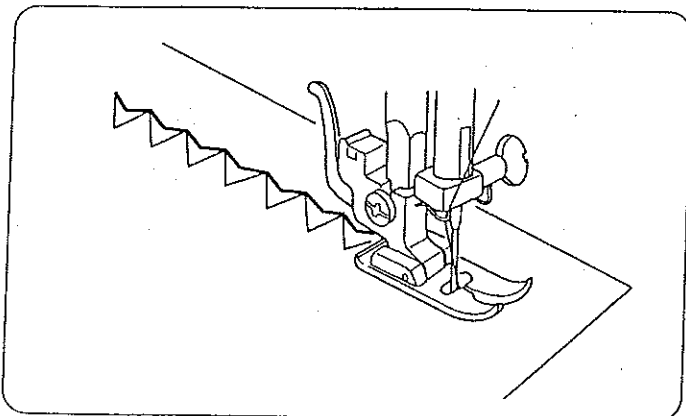

If forward and reverse feeds become unbalanced due to the type of fabric, adjust the balance by turning the stitch length dial as follows:

If patterns are compressed, turn the dial toward "+".  
If patterns are drawn, turn the dial toward "-".

(See page 12)

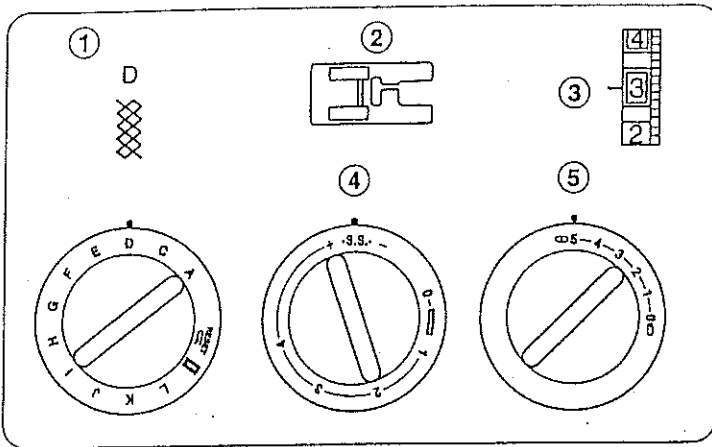

## Smocking

- ① Pattern selector: D
- ② Presser foot: Satin stitch foot
- ③ Thread tension: 1-4
- ④ Stitch length: S.S.
- ⑤ Stitch width: 5

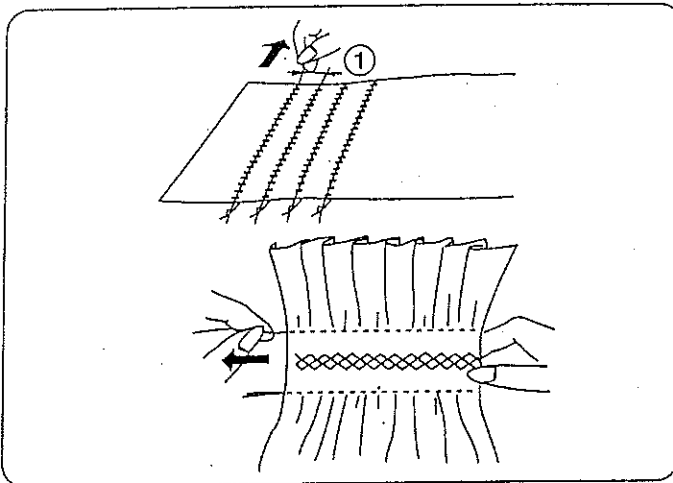

With the stitch length at "4", sew straight stitching lines 1 cm (3/8") apart, across the area to be smocked. Knot the threads along one edge. Pull the bobbin threads and distribute the gathers evenly. Secure the threads at the other end. Sew the decorative stitch between the gathering stitches. Pull out the gathering stitches.

**Note :** Loosen the needle thread tension to make gathering easier.

- ① 1 cm (3/8")

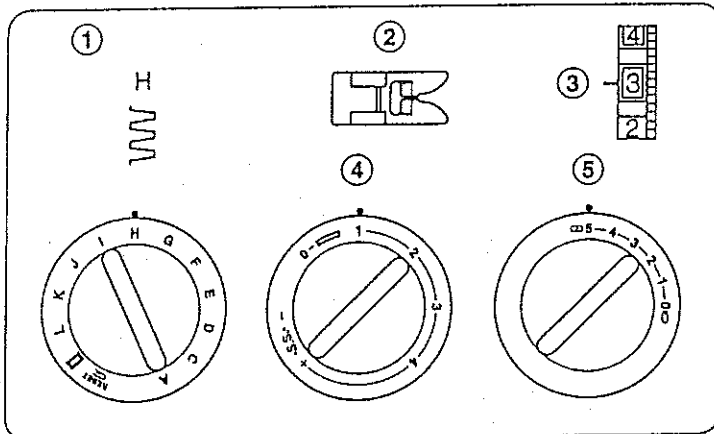

## Box Stitching

- ① Pattern selector: H
- ② Presser foot: Zigzag foot
- ③ Thread tension: 1-4
- ④ Stitch length: 0.5-2
- ⑤ Stitch width: 5

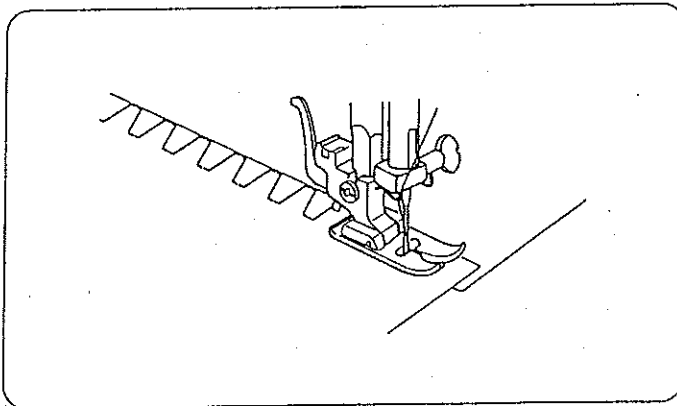

Use this stitch to join heavy weight fabrics. Overlap two raw edges together and use this stitch to join them.

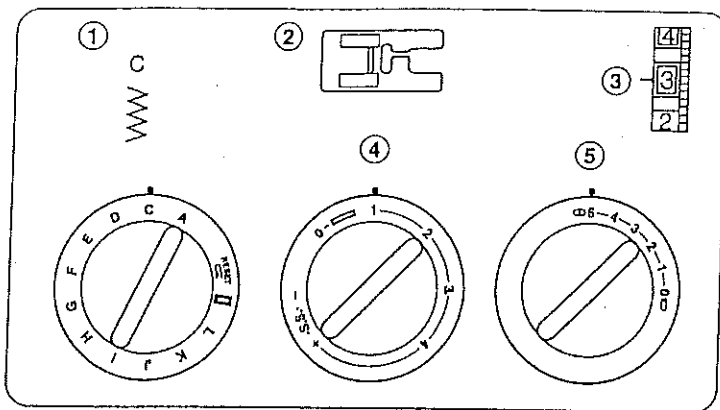

### Applique

- ① Pattern selector: C
- ② Presser foot: Satin stitch foot
- ③ Thread tension: 1-4
- ④ Stitch length: 0.5-1
- ⑤ Stitch width: 5

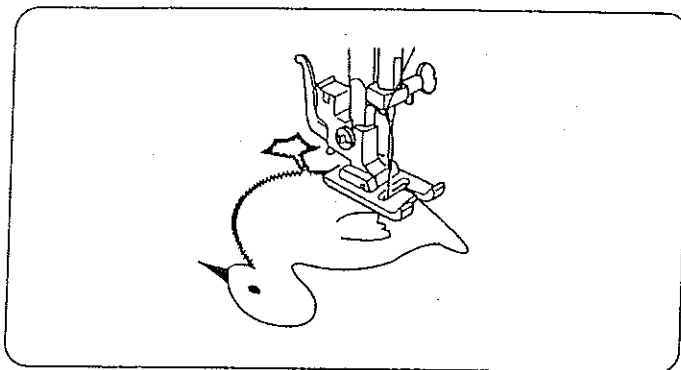

Baste (or fuse with iron-on fabric joiner) applique pieces on the fabric. Stitch around the applique making sure the needle falls along the outer edge of the applique. When sewing corners, lower the needle down into the fabric. Raise the presser foot and pivot fabric to the right or left.

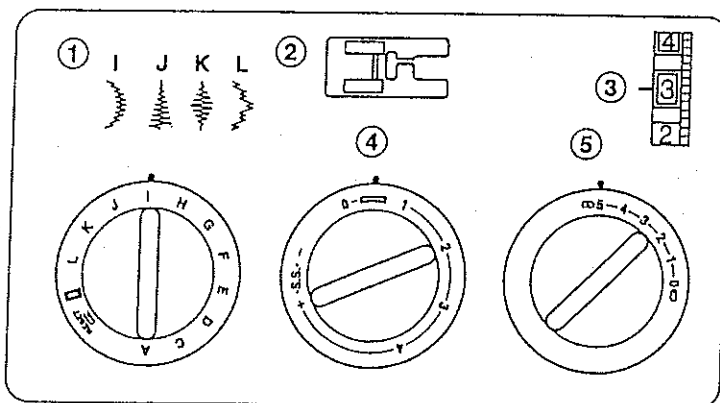

### Decorative Satin Stitch Pattern

- ① Pattern selector: I-L
- ② Presser foot: Satin stitch foot
- ③ Thread tension: 1-4
- ④ Stitch length: 0.5-1
- ⑤ Stitch width: 5

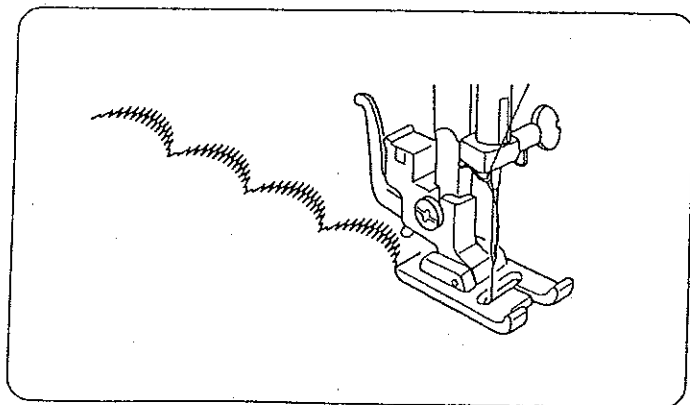

For a delicate appearance on fabric such as chiffon, use a single layer with a tear-away backing, if necessary.

## SECTION 6. CARE OF YOUR MACHINE

### Dismantling and Assembling

#### Hook Race Unit

**Note :** Turn off the power switch and/or unplug the machine.

#### To dismantle hook race unit:

Raise the needle to its highest position and open the hook cover. Open the hinged latch of bobbin case and take it out of the machine.

Open the hook race ring holders and remove the hook race ring. Remove the hook.

\* Clean the hook race with a brush and a soft dry cloth.

- ① Bobbin case
- ② Hook race ring holder
- ③ Hook race ring
- ④ Hook
- ⑤ Hook race

#### To assemble hook race unit:

Hold the hook by the centre pin and fit it carefully back into the hook race, forming a perfect circle with the shuttle driver.

Attach the hook race ring making sure the bottom pin fits into the notch.

Lock the hook race ring by turning the holders back into position. Insert the bobbin case.

- ⑥ Pin
- ⑦ Notch

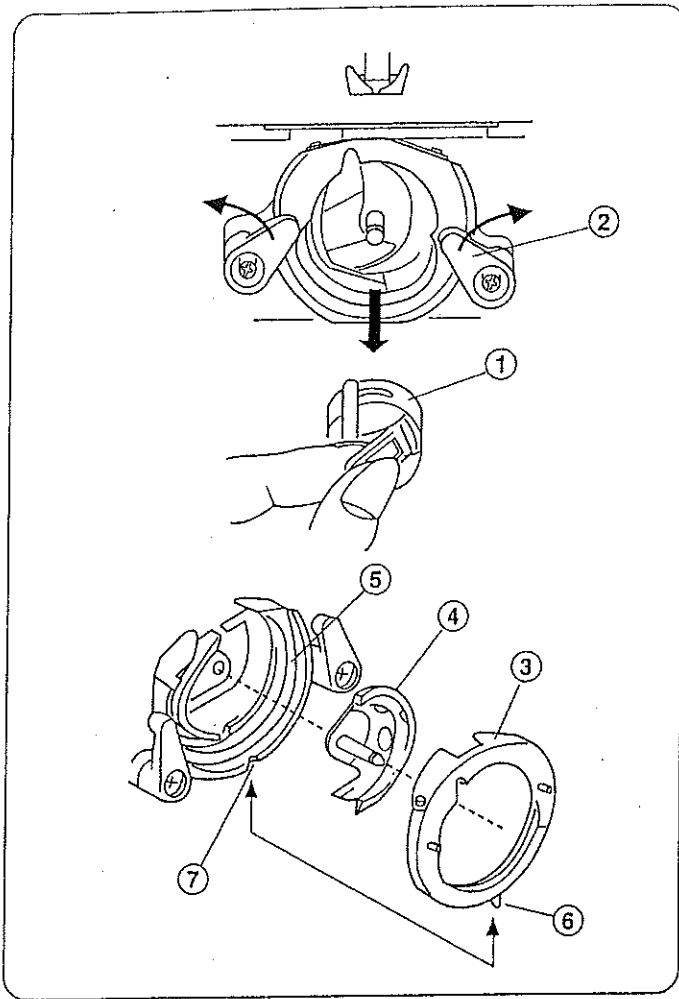

#### Cleaning the Feed Dog

**Note :** Turn off the power switch and/or unplug the machine before cleaning the feed dog.

Remove the needle and the presser foot.

Remove the needle plate set screw and remove the needle plate.

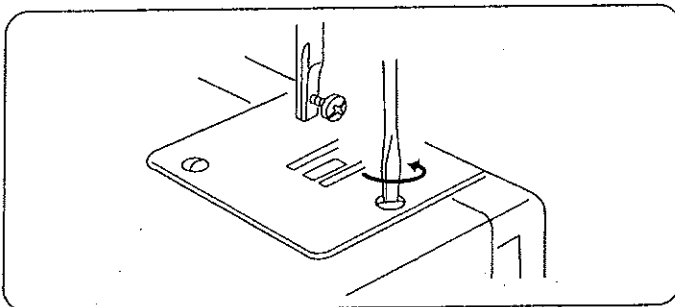

With a brush, clean out dust and lint clogging the feed dog teeth. Reset the needle plate.

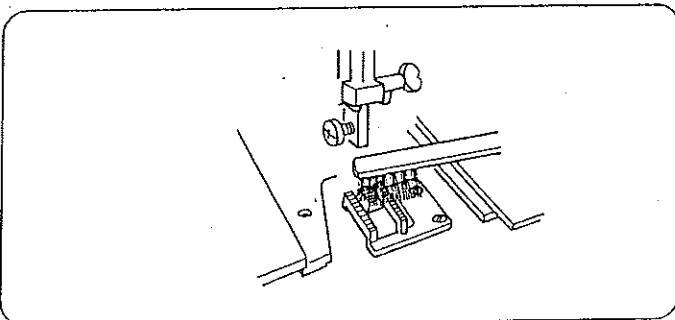

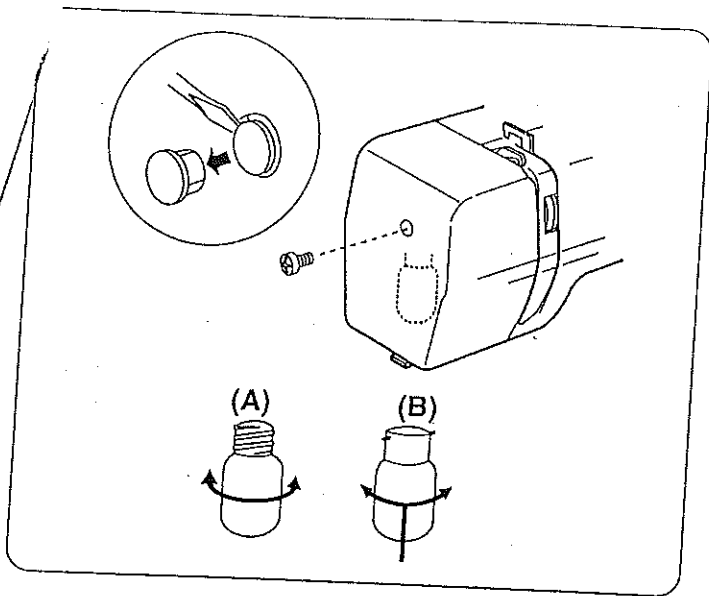

## Sewing Light

The sewing light is located behind the face plate.  
To change the bulb, take the face plate off the sewing machine by removing the setscrew.

- \* Unplug the power supply before changing the bulb.
- \* Do not dismantle the machine other than explained in this manual.

- (A)
- To remove ..... Turn to the left.
  - To replace ..... Turn to the right.
- (B)
- To remove ..... Push and twist to the left.
  - To replace ..... Push and twist to the right.

**Warning :** The bulb could be HOT. Protect your fingers when handle it.

## Troubleshooting

Condition	Cause	Reference
The needle thread breaks.	<ol style="list-style-type: none"> <li>1. The needle thread is not threaded properly.</li> <li>2. The needle thread tension is too tight.</li> <li>3. The needle is bent or blunt.</li> <li>4. The needle is incorrectly inserted.</li> <li>5. The fabric is not being drawn to the back when sewing is finished.</li> <li>6. The thread is either too heavy or too fine for the needle.</li> </ol>	<p>See Page 9 See Page 11 See Page 6 See Page 6 See Page 14 See Page 6</p>
The bobbin thread breaks.	<ol style="list-style-type: none"> <li>1. The bobbin thread is not threaded properly in the bobbin case.</li> <li>2. Lint has collected in the bobbin case.</li> <li>3. The bobbin is damaged and doesn't turn smoothly.</li> </ol>	<p>See Page 8 Clean the bobbin case. Exchange bobbin.</p>
The needle breaks.	<ol style="list-style-type: none"> <li>1. The needle is incorrectly inserted.</li> <li>2. The needle is bent or blunt.</li> <li>3. The needle clamp screw is loose.</li> <li>4. The tension of the needle thread is too tight.</li> <li>5. The fabric is not drawn to the back when sewing is finished.</li> <li>6. The needle is too fine for the fabric being sewn.</li> <li>7. The pattern selector dial had been turned while the needle was in the material.</li> </ol>	<p>See Page 6 See Page 6 See Page 6 See Page 11 See Page 14 See Page 6 See Page 12</p>
Skipped stitches	<ol style="list-style-type: none"> <li>1. The needle is incorrectly inserted.</li> <li>2. The needle is bent or blunt.</li> <li>3. The needle and/or threads are not suitable for the work being sewn.</li> <li>4. A BLUE TIPPED needle is not being used for sewing stretch, very fine fabrics and synthetics.</li> <li>5. The needle thread is not threaded properly.</li> </ol>	<p>See Page 6 See Page 6 See Page 6 See Page 6 See Page 9</p>
Seam puckering	<ol style="list-style-type: none"> <li>1. The needle thread tension is too tight.</li> <li>2. The machine is not threaded correctly.</li> <li>3. The needle is too heavy for the fabric being sewn.</li> <li>4. The stitches are too coarse for the fabric being new line sewn.</li> </ol> <p>* When sewing extremely light weight materials, place a sheet of paper underneath the fabric.</p>	<p>See Page 11 See Page 9 See Page 6 Make the stitches denser.</p>
Stitches form loops below the work	<ol style="list-style-type: none"> <li>1. The needle thread tension is too loose.</li> <li>2. The needle is either too heavy or too fine for the thread.</li> </ol>	<p>See Page 11 See Page 6</p>
The cloth is not feeding smoothly.	<ol style="list-style-type: none"> <li>1. The feed dog is packed with lint.</li> <li>2. The stitches are too fine.</li> </ol>	<p>See Page 28 Make the stitches coarser.</p>
The machine does not work.	<ol style="list-style-type: none"> <li>1. The machine is not plugged in.</li> <li>2. Thread is caught in the hook race.</li> <li>3. Handwheel has been disengaged for bobbin winding.</li> </ol>	<p>See Page 4 See Page 28 See Page 8</p>
The machine does not run smoothly and is noisy.	<ol style="list-style-type: none"> <li>1. Threads have been caught in hook mechanism.</li> <li>2. The feed dog is packed with lint.</li> </ol>	<p>See page 28 See Page 28</p>